

Off-Air Antenna Installation Guide

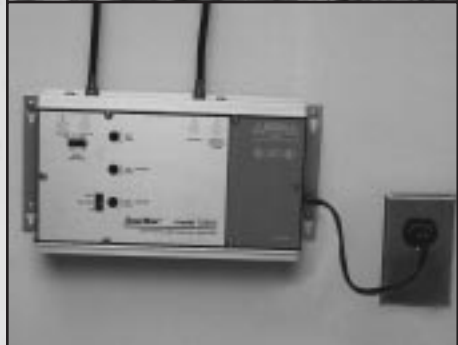

Solutions For
The Professional Installer



INTRODUCTION

The information in this manual has been gathered from some of the most experienced antenna installation professionals in the country and compiled by Channel Master® field engineers. It is intended for technicians who are, or plan to become professional antenna installers. Any handy "do-it-yourself" consumer can mount an antenna, run transmission line and pull in some kind of a signal. But only a professional can select and precisely install the correct antenna and assure his customers years of superior TV/FM reception.

Back in the 1940s, TV antennas were actually manufactured by hand at the installation site. Each antenna was assembled, piece by piece, at the customer's home. Channel Master eliminated this time-consuming labor by introducing the first preassembled TV antenna, providing excellent reception in all areas and at reasonable prices.

Today medium-to-high gain, broadband antennas are essential for good reception. Even the most expensive color TV or FM stereo receiver can't perform to full potential without the strong signals that only a quality antenna system can provide.

Advanced antenna theory and design is not included in this manual. The greatest emphasis is on practical, time-tested methods and procedures for properly installing TV and FM antennas. With this foundation of knowledge, you can build your reputation as a professional antenna installer—one who is capable of assuring his customers the finest performance from today's sophisticated TV and FM equipment.

A WORD ABOUT ANTENNA SPECIFICATIONS

Sensitivity ratings are based on optimum conditions over unobstructed terrain. What lies between a transmitter and an antenna installation will have a direct bearing on what type of antenna is appropriate.

Factors to consider are: the power output and height of a transmitting antenna tower, the type of terrain between the tower and the receiving antenna, and the size and number of buildings that lie in the path of the transmission.

All Channel Master VHF/FM and UHF/VHF/FM antennas have sensitivity classifications such as "fringe," "suburban," "deep fringe," etc. These classifications are designed to indicate at what distance from a TV transmitter the antenna will provide the best reception. Our antenna lab has computed the following chart as a general guide:

Area Designation	For VHF	For UHF
Deepest Fringe	100+ miles	60+ miles
Deep Fringe	100 miles	60 miles
Fringe	80 miles	45 miles
Near Fringe	60 miles	40 miles
Far Suburban	50 miles	35 miles
Suburban	45 miles	30 miles
Far Metropolitan	30 miles	25 miles
Metropolitan	25 miles	15 miles

Additional performance information is available from Channel Master upon request. Write to:

Channel Master
P.O. Box 1416
1315 Industrial Park Drive
Smithfield, NC 27577

Or contact us through our site on the World Wide Web at:

www.channelmaster.com

CHAPTER ONE: ANTENNA SELECTION

Basically, a receiving antenna is a device for intercepting the electromagnetic waves or signals, sent from a transmitter. Some antennas are simple vertical poles; others are small wire loops attached to the back of a TV set.

In this manual, we will discuss the outdoor TV antenna design with which most of us are familiar: a central horizontal boom with small elements attached at right angles.

The main receiving element of an antenna is called the dipole (Fig. 1-1). All of the other antenna parts are designed primarily to help the dipole do its job. The dipole consists of two half-elements to which the transmission line is attached. It is the element around which the other antenna parts are designed and positioned.

BASIC TV ANTENNA TYPES

TV antennas can be grouped in four major functional categories: VHF/FM, UHF, UHF/VHF/FM, and FM only combinations.

VHF and FM Antennas

Most VHF (Very High Frequency) antennas are engineered to receive TV channels 2 through 13. They also will receive the FM radio band, which is located between TV channels 6 and 7. FM only antennas are available also (Figure 1-6). Channels 2 through 6 are known as the low band. Channels 7 through 13 are referred to as the high band. Some VHF antennas are designed to receive only one band, either the low or high band. Antennas designed to receive both the low band and the high band are called VHF/FM broad-band antennas (Figure 1-2).

TV channel 1 “disappeared” in the early days of TV because of a change in frequency assignments by the Federal Communications Commission (FCC). A reshuffling of FM, Amateur, and other bands removed TV from the frequencies previously reserved for TV channel 1. Because the other 12 TV channels were already numbered 2 through 13, the channel 1 designation simply was dropped.

UHF Antennas

UHF (Ultra High Frequency) antennas are designed to receive TV channels 14 through 69, the UHF TV band. The UHF TV band originally extended from channel 14 to channel 83. However, the FCC now has reassigned channels 70 through 83 (also known as the translator band) to mobile communications use. Although there still are many antennas capable of receiving all 82 channels, the translator band (former TV channels 70-83) is useless to the TV viewer. UHF TV antennas come in a wider variety of shapes and sizes than

VHF/FM antennas. The wider variety of UHF designs (Figure 1-3) is possible because they don't require the long elements that VHF/FM antennas do.

Combination UHF/VHF/FM Antennas

Combination UHF/VHF/FM TV antennas are designed to receive both the UHF and the VHF/FM bands. Although the use of separate antennas for each band is ideal for peak reception, high-performance UHF/VHF/FM combination models are readily available and are becoming increasingly more popular. Examples of combination UHF/VHF/FM antennas are shown in figures 1-4 and 1-5.

HOW TO SELECT THE RIGHT ANTENNA

There are many bands and hundreds of TV antenna models available. However, choosing the right one is relatively easy if you are aware of a few basic reception and TV antenna characteristics.

First, “good reception,” or production of a snow-free color TV picture, requires a signal level of about 1000 microvolts (μV) = 1 millivolt (mV). To deliver this signal level to the receiver, the antenna requires a certain antenna gain. The amount of gain required is dependent on the distance between the station's transmitting antenna and the receiving antenna. The required type of antenna therefore depends on the channels to be received and the distance and direction of the customer's home from the transmitting antennas. These facts are readily available for any area, but be sure your information is accurate and complete. Call a local TV station if you have questions. Most TV stations are willing to help TV antenna installers because they also benefit from the improved reception to the station's viewers.

Be sure to discuss with your customers the number and types of channels that are receivable. This may sound basic, but your customers may not understand the difference between VHF/FM and UHF. They also may not be aware that with the right equipment they may be able to receive out-of-town channels, some of which may carry sports programs that are locally blacked out. The most important points to remember when selecting an antenna are its gain, sensitivity classification, directivity, and front-to-back ratio.

Gain

The gain of an antenna indicates the relative strength of signal it can deliver to a receiver. Most manufacturers list the gain of their antennas in decibels (dB). The higher the antenna gain, the stronger the signal at the antenna output terminals. In most cases, the larger the antenna, the higher the gain.

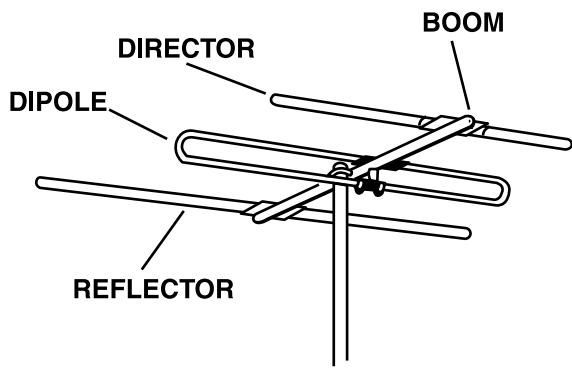

Fig. 1-1. The principal parts of a basic Yagi-type TV antenna.

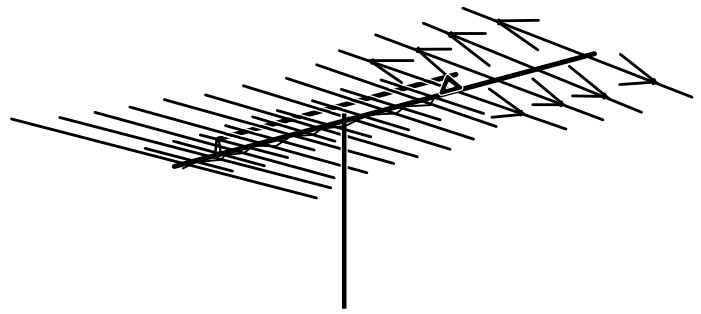

Fig. 1-2. A VHF/FM broadband TV antenna.

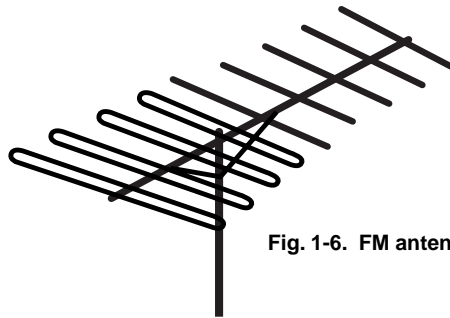

Fig. 1-6. FM antenna.

Fig. 1-3. Various designs of UHF TV antennas.

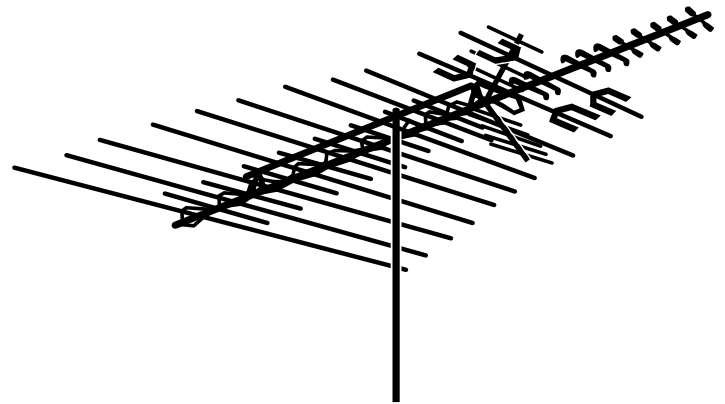
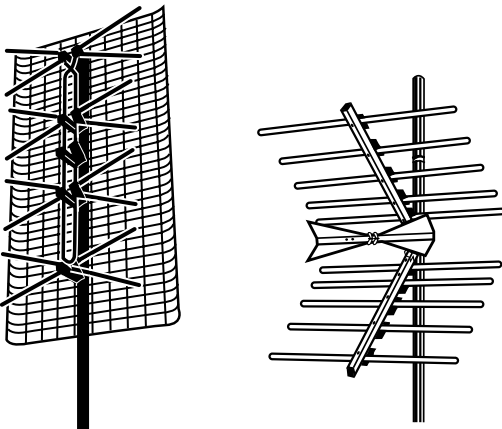
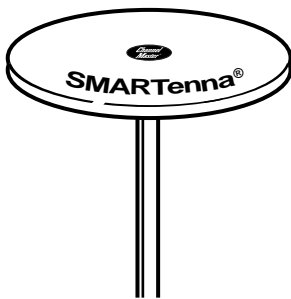

Fig. 1-5. Channel Master® CROSSFIRE® UHF/VHF/FM TV antenna.



Channel Master® SMARTenna® UHF/VHF Antenna

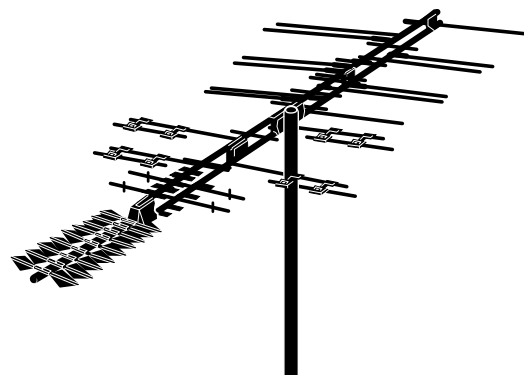

Fig. 1-4. Channel Master® QUANTUM® model UHF/VHF/FM antenna.

If you are in doubt about the amount of gain required, select an antenna that is slightly larger than you think is actually needed. The performance of all components deteriorates slightly during the years they are exposed to rain, sun, wind, and corrosion. Consequently, to ensure quality reception for a longer period, choose an antenna with a little more gain than is necessary. (Note: Excessive gain may cause overloading. Therefore, choosing the antenna with the highest gain might create more reception problems than it cures.)

Sensitivity classifications are used to indicate the type of reception area for which the antenna is designed. Certain ranges of gain are best suited for certain types of areas. The appropriate range of gain for a specific area is what a manufacturer is indicating when labeling an antenna. Outer Suburban or Near Fringe Table 1-1 is a chart of typical sensitivity classifications. It indicates in miles, how close an antenna must be to the transmitter to produce the best signal level. The classifications are somewhat general because reception conditions at various sites within a particular type of area may be different.

DIRECTIVITY

Directivity is the ability of an antenna to intercept signals from only one direction and reject those from other directions. Directivity indicates the antenna's ability to intercept signals arriving at its front and reject signals coming from the sides and rear. Generally, the more highly directive an antenna, the better it can reject signals from the sides and rear.

The front-to-back ratio of an antenna can be helpful when attempting to determine its directivity. Front-to-back ratio is expressed in decibels (dB) and can be found in the literature accompanying a new antenna. This ratio indicates an antenna's ability to reject signals coming from the rear (rear rejection). For example, an antenna with a front-to-back ratio of 25 dB will receive about 18 times more signal strength from the front than from the back.

In most cases, an acceptably accurate estimate of an antenna's directivity can be made by comparing its specified front-to-back ratio with the relative sensitivity classifications listed in Table 1-1.

The sensitivity classifications in Table 1-1 are intended only as general guidelines for evaluating directivity. Other factors, such as the antenna's beamwidth, can affect its directivity. Beamwidth is related to an antenna's overall gain and indicates how wide or narrow the antenna's reception area is. For example, if two antennas have the same front-to-back ratio, the one with the highest overall gain will have the narrowest beamwidth and consequently, will be the most directive.

An antenna with a relatively narrow beamwidth generally is best suited for areas where interference from sides is a problem. An antenna with a broad beamwidth is best suited for areas where a broad beam is needed to capture the signals from widely separated stations, and where interference is minimal. Beamwidth information, if included by the manufacturer, is usually displayed by use of polar plots like the one in Figure 1-6.

Selecting the most suitable antenna becomes easy with experience, but selecting quality materials should be the first decision to make before starting any installation. High-performance color reception usually requires highly sensitive equipment. In the long run, it pays to use the finest equipment available, from the antenna down to the receiver end of the transmission line. The slight additional cost should be considered an investment in longer system life and optimum performance.

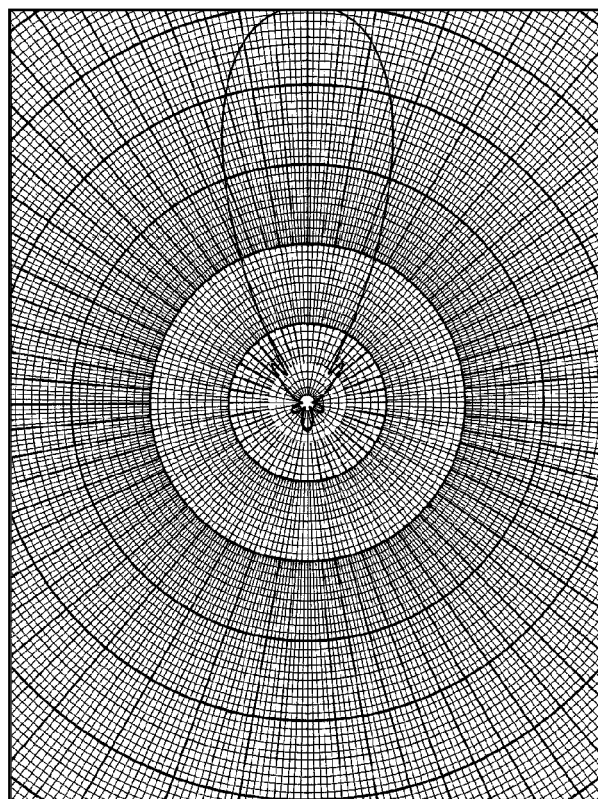

Fig. 1-6. A polar plot like shown here reveals the directivity and beamwidth of an antenna.

Area Designation	For VHF	For UHF
Deepest Fringe	100+ miles	60+ miles
Deep Fringe	100 miles	60 miles
Fringe	80 miles	45 miles
Near Fringe	60 miles	35 miles
Far Suburban	50 miles	35 miles
Suburban	45 miles	30 miles
Far Metropolitan	30 miles	25 miles
Metropolitan	25 miles	15 miles

Table 1-1. Typical Sensitivity Classifications

CHAPTER TWO: SAFE INSTALLATION PROCEDURES

There are extremely important safety factors to consider. Learning and following simple safety precautions can, quite literally, save your life. Following safe procedures also helps prevent costly damage to your equipment and your customer's property.

No list of safety tips can cover every potential hazard. Consequently, careful planning, common sense, and good judgment must be used at all times.

1. Locate and avoid power lines and other wires in the work area.
2. Do not climb on a wet or icy roof.
3. Do not attempt high installations on windy days.
4. Do not hesitate to turn down a job that seems too dangerous.
5. Use only the sturdiest commercial-grade ladders. (Types with wide, slip-preventive rungs and bases are essential. Avoid types with round rungs.)
6. Do not position ladders at an angle steeper than 70°. Steeper angles can cause a ladder to slip sideways.
7. Dig the base of the ladder into the ground if possible.
8. Do not place ladders on slate that is wet or hot. Wet or sun-heated slate is very slippery.
9. Do not climb on roofs that have curled or worn shingles. (Old shingles break easily or pull out.)
10. Wear seasonable clothing that is neither too tight nor too loose. Wear snugly-fitting rubber-soled, low-heeled shoes or boots.
11. Wear a pair of durable but flexible protective gloves whenever they will not interfere with the work process.
12. Carry a well-equipped first aid kit in your truck.
13. Keep a couple of cans of wasp and hornet spray that will shoot with a long stream.
14. Have an effective insect repellent handy during spring and summer months. (Wipe off your hands after applying it.)
15. Any antenna mounted on 20 or more feet of mast requires more than one person to install.
16. Carefully survey the job before beginning the installation to locate secure handholds, dangerous conditions (such as power lines and weak roofs), and the safest and most convenient placements for ladders.
17. Do not climb onto a roof when there is no one else around.
18. Be sure all of your helpers know and follow safe procedures.
19. Do not step into roof valleys (the area where two roofs join); they often are weak, even on new homes.
20. Do not install antennas under large, overhanging tree branches if it can be avoided.
21. Buy only the best quality tools and equipment. Besides lasting longer, top-quality tools and equipment generally do not break or bend as readily as do cheaper products.
22. Antennas must be installed away from power lines a distance equal to at least twice the combined length of the mast and antenna.
23. Refuse to perform jobs that are not directly related to the antenna installation. If you do and a liability problem develops, your insurance probably will not cover it.

Thoroughly plan every installation. Carefully think through the job, and don't take dangerous shortcuts.

CHAPTER THREE: MOUNTING FOR OPTIMUM SIGNAL STRENGTH

Ideally, an antenna should be mounted at the point where the signals are the strongest, though often this is impractical or impossible. Also, the antenna should be mounted where it can be easily serviced should repairs or adjustments be required in the future. So carefully "aiming" (orienting) the antenna and adjusting its height often can overcome the problems created by installing it in a slightly weaker signal area.

In an area where there is a relatively short, unobstructed signal path between the installation and the transmitting towers, you can mount the antenna just about anywhere and receive sufficient signal. As you move deeper into the fringe areas however, there may be significant differences in signal strength at various points on the roof. This is where careful antenna selection, precise orienting, and accurate adjustment of the height become essential. The careful installer should be able to locate a spot where there is both a usable signal and sufficiently easy access to the antenna.

Large trees can present reception problems and nearby high-voltage power lines can cause interference that cannot be completely eliminated. Consequently, the further the antenna is from large trees and high-voltage lines, the better the reception will be.

WALKING THE ROOF FOR OPTIMUM SIGNAL STRENGTH

"Walking the roof" is usually the best way to find the spot on the roof where the strongest signals are present. First, attach a small TV antenna to short mast (4-6 feet). Attach one end of a short transmission line to the antenna terminals. Attach the other end of the transmission line to the input jack of a field-strength meter. Then walk to the most suitable mounting areas. Point the front of the test antenna in the general direction of the transmitter tower(s). Slowly, rotate the antenna while carefully watching the field-strength meter. (Most field strength meters are equipped with shoulder straps that free both of your hands for manipulating the antenna.)

USING A FIELD-STRENGTH METER

A small, battery-powered portable TV is helpful for determining general reception quality. However, there is no better way to determine actual signal strength than to use a field-strength meter (Figure 3-1). It is one of the best investments you can make. The meter will save you so much time and trouble that it will quickly pay for itself.

Fig. 3-1. A field-strength meter.



Field-strength meters come with detailed operating instructions. Below are general characteristics and operating procedures that apply to most field-strength meters.

A field strength meter has an input impedance of 75 ohms. Most television antennas have an output impedance of 300 ohms. For accurate measurements these two impedances must be "matched." Attach a balun (matching transformer) to the antenna terminals and run coaxial cable from the balun to the meter input jack. (TV coaxial cable has an impedance of 75 ohms.)

Most field-strength meters will measure the strength of both VHF and UHF signals and will separately measure each channel. Most field strength meters will also separately measure the picture and sound signals of each channel.

The ideal is to get the strongest signal possible. When this is not possible and you need to sacrifice a little strength, connect the test antenna output to a battery operated, portable TV set and check the picture and sound to ensure that the signal levels are adequate for acceptable reception. The TV will also help you better explain reception possibilities and problems to your customers.

A field-strength meter indicates signal strength in microvolts (μV) and decibels relative to one millivolt (dBmV). One microvolt is one-millionth of a volt, or 0.000001 volt. The microvolt reading is probably the easiest to use. As a general guideline, a signal level of 50 μV at the antenna output terminals is the weakest usable signal; however, it will require strong preamplification to provide acceptable TV reception.

Antenna output signals of 500 μV and above are considered adequate. Any signal level below 1,000 μV will require preamplification.

To use the field-strength meter, orient your test antenna in the direction of incoming signals and activate the meter. To orient the actual installed antenna in an area where several channels are coming from the same general direction, aim the antenna to obtain the highest reading with the field-strength meter set on the highest channel to be received. (Channel 13 is the highest VHF channel, and 69 is the highest UHF channel.) As a result, this will orient the shortest antenna element as well as properly align remaining elements. Of course, if the channels are coming from different directions, you will have to take separate readings for each and adjust the antenna(s) accordingly.

ADJUSTING THE HEIGHT FOR OPTIMUM SIGNAL STRENGTH

Just as the received signal strength varies with the mounting site and the direction in which the antenna is pointed (oriented), the height at which the antenna is installed will also affect signal strength. A few feet up or down may make a big difference in the level of the received signal(s), especially on UHF channels. Watch your field-strength meter as you slowly raise and lower the test antenna.

The height at which you ultimately mount the antenna depends on two things: signal strength and practicality. You should mount the antenna only as high as necessary, even if your meter indicates that the signal level continues to increase as you raise the antenna. Choose the height at which you get the highest signal level without having to resort to guyed mast and other more expensive and difficult to install equipment. Your objective should be to get as close as possible to an unobstructed "line of sight" between the transmitter tower(s) and the receiving antenna so that the signal clears all large buildings and other obstructions.

In some cases, obtaining adequate signals may require the installation of a multiple array. A multiple array is two or more antennas set at different heights on the same mast (Figure 3-2). Ideally, these antennas should be spaced seven feet apart so that they won't interact with each other. If this is not practical, try to mount them at least five feet apart. When installing more than one antenna on a mast, try to mount the largest (heaviest) at or near the mast support. This will help prevent excessive strain on the mast during high winds.

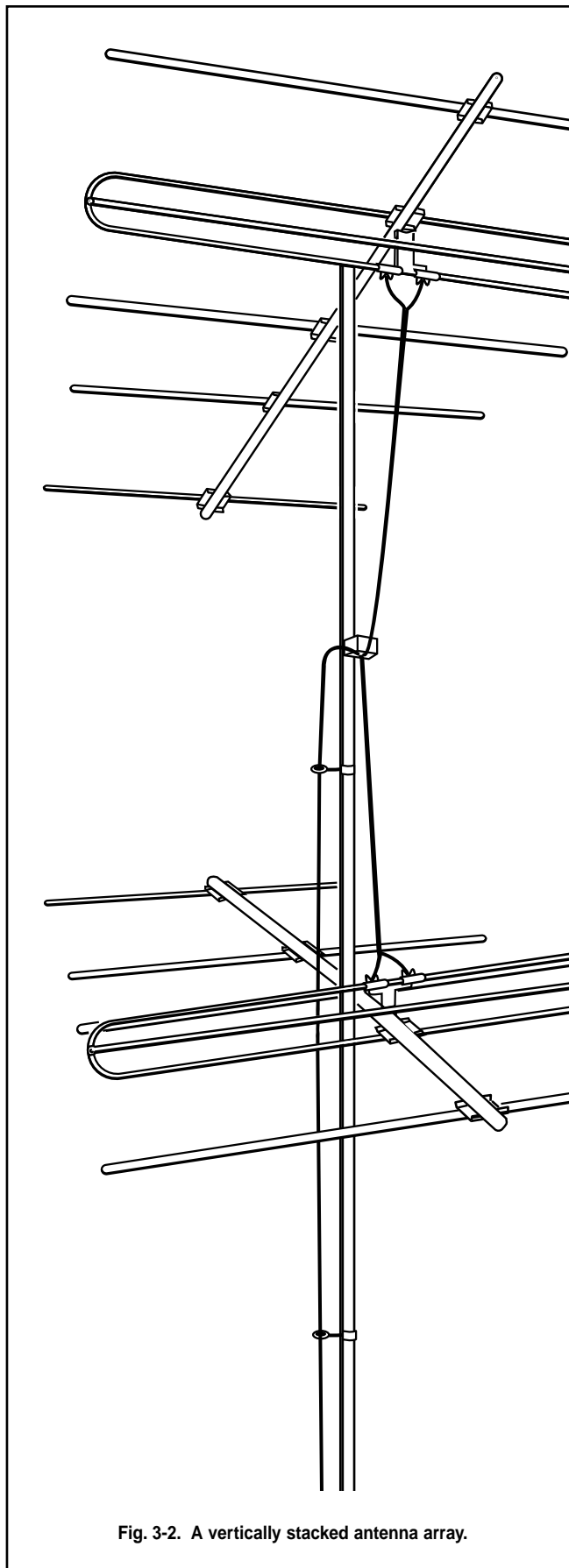

Fig. 3-2. A vertically stacked antenna array.

CHAPTER FOUR: TOOLS, MASTS & HARDWARE REQUIREMENTS

Tools

The majority of the tools and equipment you will need for most installations are apparent. The following is a list of useful tools and miscellaneous materials that might also come in handy.

1. A complete set of nut drivers (spin-tights).
2. A set of ratchets and sockets.
3. A pocket compass, for orienting the antenna and setting up the rotor when the compass bearing(s) of the transmitter tower(s) is known.
4. A drill brace with a wide assortment of bits.
5. A good quality leather tool belt.
6. A crimping tool for fastening coaxial connectors.
7. Caulking compound for sealing the holes where transmission line enters the house.
8. Roofing tar (plastic roof cement), for sealing around screws on the roof.
9. Silicone grease for waterproofing coaxial cable connectors.
10. A sledge hammer for driving in ground rods.
11. A level or plumb bob for ensuring that the antenna mast is installed perpendicularly.
12. A map to aid antenna orientation. (Aircraft maps are ideal. Most airports sell them.)
13. A strong step ladder (in addition to extension ladders).
14. A magnetic stud finder.
15. A small, portable TV that operates on both standard house current (117 volts AC) and batteries.

Masts

Most antenna hardware catalogs list a wide variety of mounts and masts. Most however, are variations of a few basic types. By taking into account signal strength and ease of installation, it's not difficult deciding which site, mount, and hardware to use.

A mast (Figure 4-1) is used in every installation. The mast is the vertical tubing that supports the antenna. Conventional masts are available in 5 and 10 foot lengths. Telescoping mast units (Figure 4-2) are available in 20, 30, 40 and 50 foot lengths. Each type is available in various wall thicknesses that provide different degrees of strength and rigidity. Your choice will depend on the height, weight, and size of the antenna being installed and also on wind conditions in the area.

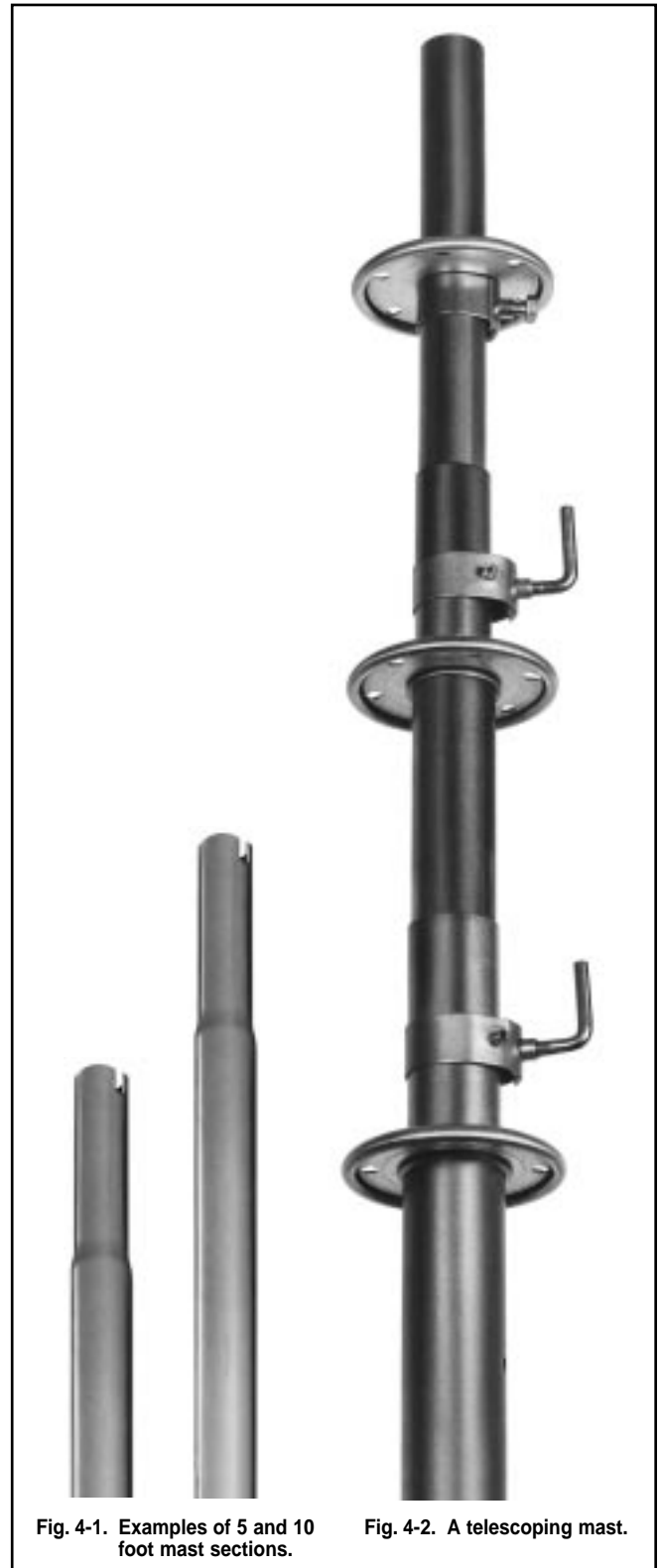

Fig. 4-1. Examples of 5 and 10 foot mast sections.

Fig. 4-2. A telescoping mast.

Both conventional and telescoping masts are available in galvanized steel and in high-tensile, acrylic-coated steel. Acrylic-coated masts are preferable because of their greater strength and durability.

MOUNTING SITES AND RELATED PROCEDURES

Attic Installations

An attic installation (Figure 4-3) may work in areas where strong signals are present. In most cases, an attic installation is the easiest, fastest, most economical, and most convenient installation. There are a few conditions however that can prohibit an attic installation. Shallow attics that are obstructed by rafter supports may not accommodate the size antenna required for the installation. Most attics are not large enough to accommodate multi-antenna arrays and rotors. Also, aluminum foil on insulation, aluminum or steel siding, metal gutters at the attic level, and metal lath under older plaster walls all can interfere to some degree with reception.

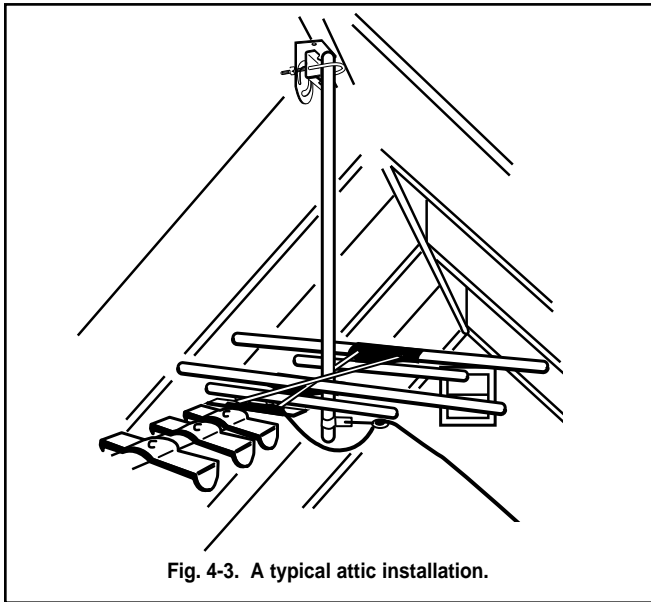

Fig. 4-3. A typical attic installation.

To determine if an attic installation is suitable, take a test antenna, a field-strength meter and a portable TV up into the attic and check the signal level and picture quality. If the signal level is sufficient and there is room enough to properly orient the antenna, assemble the antenna in the attic and attach one end of the transmission line to the antenna terminals. Then prepare the mount for the antenna.

Several roof-type mounting brackets (Figure 4-4) and swivel mounts (Figure 4-5) are adaptable for use in attic installations. The mounting bracket is used to attach the short mast to a rafter or rafter support. The antenna is then mounted on the other end of the mast. The antenna however, must not touch the attic floor. Also, remember that the antenna should be attached to the mast right side up, even though the installation appears to be the reverse of an outside installation.

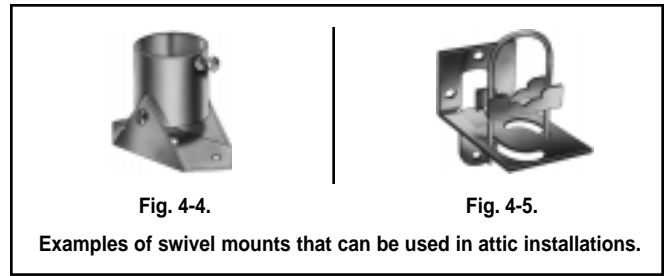

Fig. 4-4. Fig. 4-5.
Examples of swivel mounts that can be used in attic installations.

An alternative method of mounting the mast is to flatten one end of the mast with a hammer and drill a hole in it through which a nail, screw, or bolt can be inserted for securing the mast to a rafter or rafter support. However, this method requires more time and effort than does the bracket method.

Instead of using a mast, you may suspend the antenna from the inside of the roof with guy wires or nylon rope. But don't let the guy wires touch the antenna elements. They will short out the antenna.

Once you have the antenna mounted or suspended, you are ready to run the transmission line. If at all possible, keep it indoors. Coaxial cable (Figure 4-6) is the best transmission line for any antenna installation. It should be used instead of twinlead even in attic installations. Selection and installation of the correct transmission line is described in the chapter beginning on page 15.

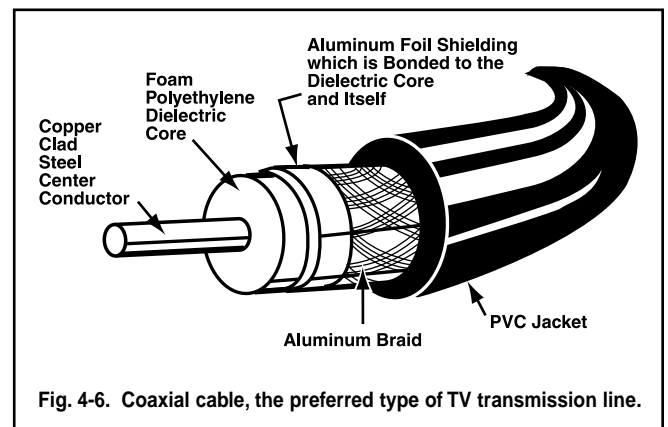

Fig. 4-6. Coaxial cable, the preferred type of TV transmission line.

After you have run the transmission line, use a compass and field-strength meter to orient the antenna toward the signal source(s). Check the picture and sound on all channels before you tighten down the clamp that secures the antenna to the mast.

Some manufacturers make special antennas for attic installations. These antennas however, tend to be omni-directional. This means they intercept signals equally well from all directions. Consequently, they will also pick up interference more readily than a good directional antenna.

Chimney Mounts

Chimney Mounts (Figure 4-7) are used more frequently than other types of mounts, but they often are not the best option. Although they are relatively easy to install, the smoke and gases from a chimney can shorten the life of the antenna and significantly impair its performance.

A chimney installation is practical only if the chimney is sturdy and vertical. Never mount an antenna on a deteriorated chimney. During moderate to high winds an unguied mast taller than 10 feet can exert enough leverage to break off an unstable chimney.

If you choose a chimney mount, use enough mast to place the antenna above most of the smoke and gases. However, to avoid overstressing the chimney, do not mount the antenna more than 10 feet above the top of the chimney. If the height of the antenna must exceed 10 feet to receive satisfactory signals, the mast must be properly guyed. (The correct method of installing guy wires is described in Chapter 7.)

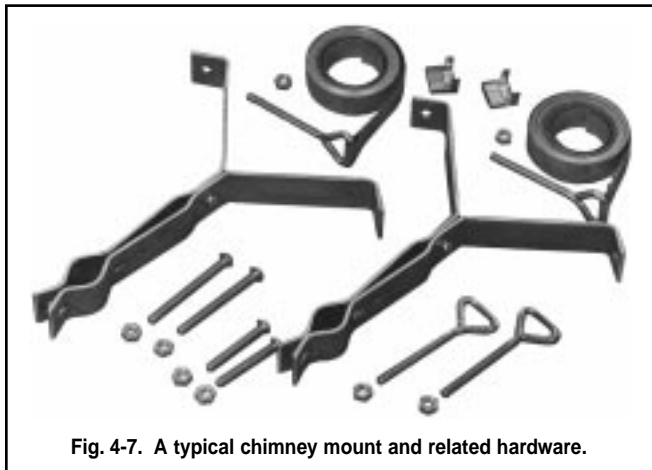

Fig. 4-7. A typical chimney mount and related hardware.

Securing the chimney-mounted antenna and minimizing the stress on the chimney requires the mounting straps to be properly spaced. The top strap should be placed as high up on the chimney as possible. If the chimney has a crown or projecting cap, place the top strap directly under it. The bottom strap should be placed 4 feet below the top strap. If the chimney isn't long enough to permit this, place the bottom strap as far down on the chimney as possible. If the mast must be 10 feet above the chimney top, don't use a chimney mount unless you can space the straps at least 30 inches apart. For masts less than 10 feet above the chimney top, the straps should be spaced no less than 24 inches apart.

Be sure the straps are level, with no kinks or twists. The easiest way to level straps is to line them up along the nearest course of bricks. Straps should be

centered on the bricks – not over the mortar joint. Pull each strap tight, line it up so that it is level, and then tighten it just enough to hold it in place.

Before the straps are tightened completely, fasten the mast to the mounting bracket. (It is assumed that the antenna has already been clamped securely to the mast, and one end of the transmission line has been connected to the antenna terminals.) Align the mast so that it is vertical. Then completely tighten the mounting straps. Next, orient the antenna. Finally, tighten the clamps that hold the mast to the mounting. Be sure the clamps are tight enough to prevent the mast from being rotated by the wind load on the antenna.

Roof Mounts

There are two basic types of roof mounts: a base mount (Figure 4-8) and a tripod (Figure 4-9).

Tripods are stronger and more rigid than base mounts, but they are also more expensive. When given a choice, use a tripod.

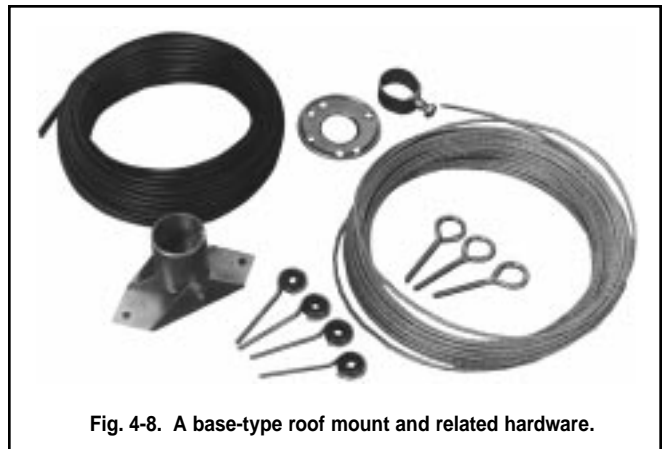

Fig. 4-8. A base-type roof mount and related hardware.

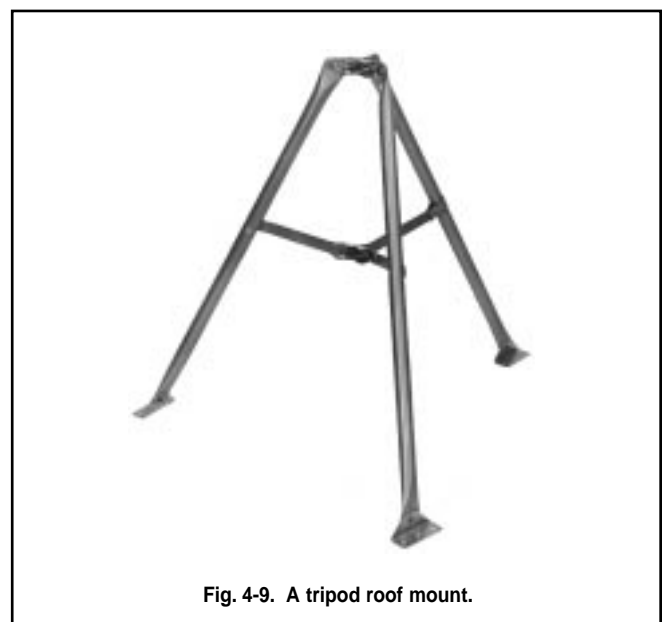

Fig. 4-9. A tripod roof mount.

However, if cost savings or limited space require it, a properly guyed base mount will usually work. Unlike a chimney mount, a base mount holds the mast at only one point, the bottom. Consequently, the mast also must be supported by guy wires, regardless of the mast length.

Correct installation of either type of roof mount requires great care and should not be attempted without a helper. Both types of mounts should be secured to the roof with either bolts or lag screws. These should be screwed into only solid wood like a rafter or a truss section. You can locate these with a stud finder.

If you must fasten the mount to the roof in an area where a bolt or screw cannot reach a rafter, send your assistant into the attic with a large square of wood 1-1/2" thick, to act as a backing plate. Have him hold this wood against the entry points of the screws or bolts so that the mount is firmly anchored in both the roof sheathing and the wooden block. This will give the mount needed stability.

When installing a base mount, attach the base plate to the roof in the manner just described, and place the mast (with antenna, guy ring, and guy wires attached), into the U-bolt that has been fastened loosely to the mount. Do not let the bottom of the mast touch the roof; it may tear a hole in the shingles.

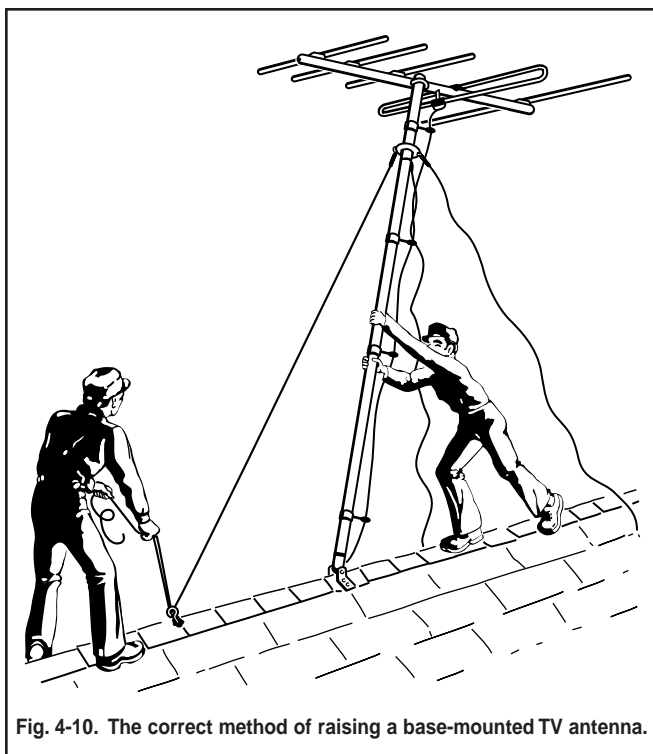

Fig. 4-10. The correct method of raising a base-mounted TV antenna.

Since a base mount must be guyed, an easy way to raise the mast is to first fasten one of the guy wire screw eyes to the roof peak on the end of the roof

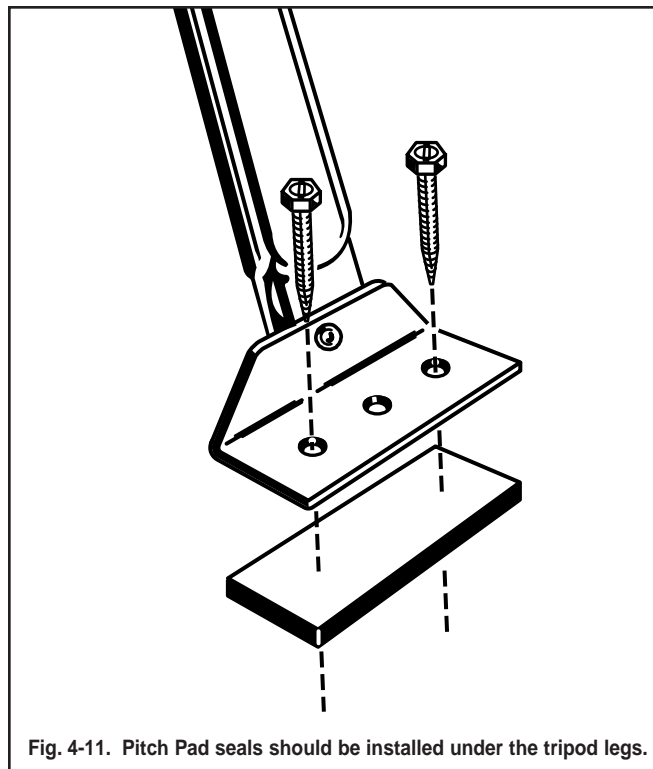

Fig. 4-11. Pitch Pad seals should be installed under the tripod legs.

opposite the direction in which the antenna is lying. Run the end of the guy wire through the screw eye. Have your assistant slowly raise the mast while you pull the guy wire through the screw eye (Figure 4-10). When the mast is vertical, the guy wire you are holding will be approximately the right length for permanent installation. Temporarily secure this guy wire. Install the other guy wires while your helper holds the mast in a vertical position. Check the mast with a level as you tighten and permanently secure each wire. When the mast is vertical and each guy wire has been tightened, orient the antenna and firmly tighten the U-bolt (clamp) on the base mount.

Tripods, as noted earlier, are a stronger, more rigid type of roof mount. The most common tripod mounts are 3, 5, and 10 feet high. The 3 foot tripod is most commonly used.

A tripod mount can be installed and leveled before the mast is inserted. It should always be mounted so that the antenna can be folded down along the peak of the roof. This will enable you to lower it more easily should repairs or adjustments become necessary in the future. Even though tripods are very stable, any tripod-mounted mast over 10 feet high should be guyed.

Ensure the sturdiness of the tripod by anchoring. To protect the roof, use a pitch pad seal under each tripod leg (Figure 4-11). Coat all lag bolts with roofing tar or other sealant to prevent leaks around them. Roofing tar or silicone should be used liberally around all holes, bolts, screws, nails, and eye screws.

Wall Mounts

Many types of wall mount brackets are available. However, many of them are poorly made and will not withstand more than a moderate wind. Buy only the best quality wall mount brackets (Figure 4-12).

When installing a wall mount, space the brackets as far apart as possible (or practical). Generally, the farther apart you space the brackets, the stronger the installation will be. Be sure the brackets extend out from the wall far enough for the mast to clear the roof eaves. As with roof mounts, screw wall mount brackets only into solid wood, and use caulking or other durable sealant around screws.

Mounting from the Ground

Many times you will not want (or will not be able) to mount an antenna on the roof. One of the best alternatives to roof mounting is mounting from the ground (Figure 4-13). With a firm base support and one or more wall mount brackets, a ground mount installation is exceptionally sturdy and long lasting. A good ground mount may also eliminate the need of guy wires.

Correctly preparing the base of a ground mount is very important. The antenna mast should rest on something more solid and stable than just bare earth. If your installation site is on a solid deck or patio, the base is already prepared for you.

When you have to prepare the base yourself, dig a hole about 2 feet deep at the spot where the mast will contact the ground. Remember that the base hole must line up with the wall bracket(s) so that the mast will be vertical. A plumb line and bob suspended from the roof eave can be used to determine the correct positions of the base hole and wall brackets (Figure 4-13). Use bricks or flat stones in the bottom of the hole as a footing to prevent the base of the mast from moving. Concrete can also be used as a footing but you'll have to wait for it to dry before you can put up the mast.

Once the base is prepared, mount a wall bracket at least 10 feet above the ground or as high as possible. Remember, the farther apart the wall brackets are placed, the sturdier the installation (Figure 4-13). If there is 5 feet or more left between the first wall bracket and the roof eave, add another wall bracket. Be sure the base hole and the wall brackets line up so that the mast will be vertical. This can be determined easily by suspending a plumb bob and line from the roof eave into the base hole. Also remember that the wall bracket(s) must extend out from the wall far enough so that the mast clears the roof eaves. Be sure the screws of each wall bracket are anchored in solid wood. Screw them into the wall studs.

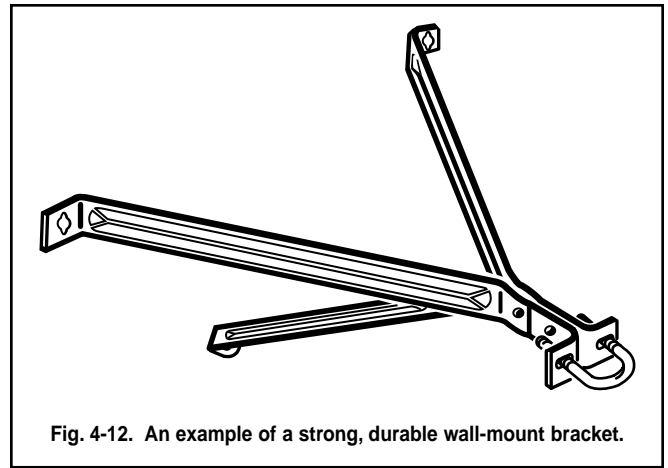

Fig. 4-12. An example of a strong, durable wall-mount bracket.

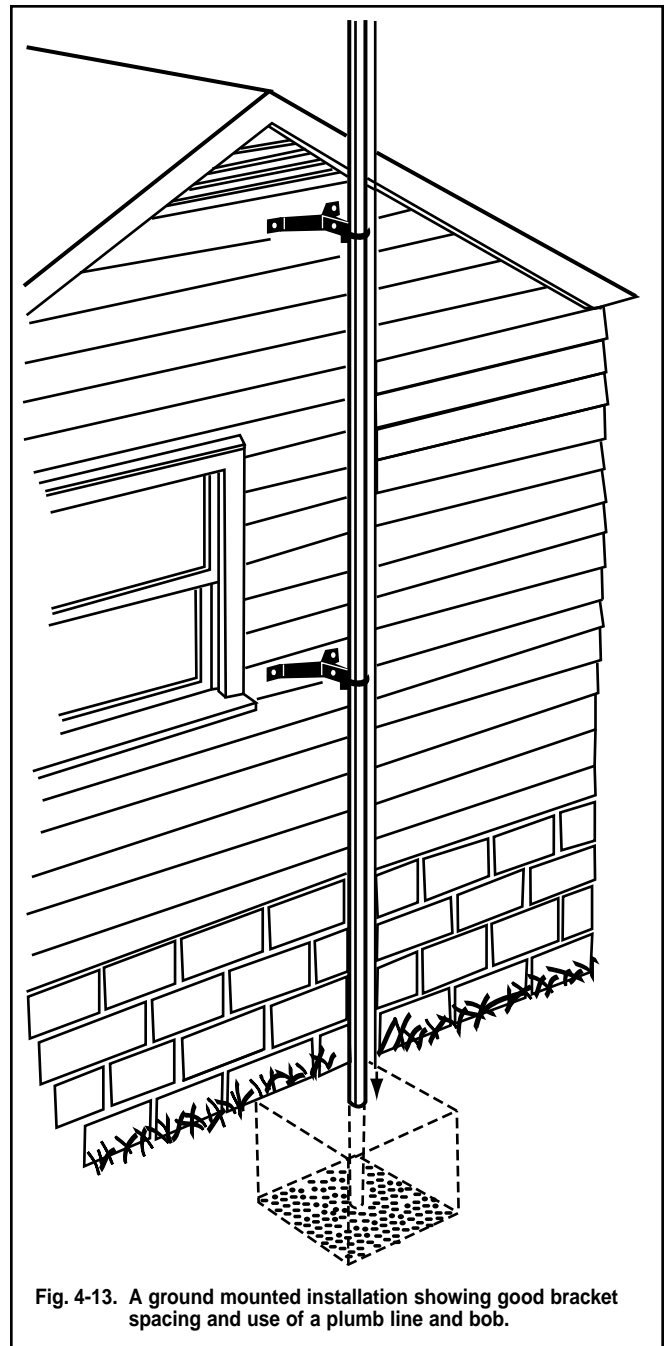

Fig. 4-13. A ground mounted installation showing good bracket spacing and use of a plumb line and bob.

Firmly clamp the antenna to the upper end of the mast. Insert the mast into the base hole or rest it on the deck or patio. Vertically position the mast by "walking" it up hand over hand. Rest it against the wall bracket(s). Loosely fasten the mast to the wall bracket(s). After determining that the mast is truly perpendicular, tighten the bracket(s) a little more. Next, orient the antenna. After the antenna has been oriented, securely tighten the wall bracket clamps around the mast. Finally, if a base hole is being used, fill in the hole and firmly tamp the soil around the base of the mast.

Telescoping Masts

A telescoping mast (Figure 4-14) is used in installations for which standard 5 or 10 foot lengths of mast stacked together would not be sufficiently strong or rigid. A length of telescoping mast is stronger and more rigid than the same lengths made up of standard mast pieces stacked together. Because of their additional strength, some telescoping masts used with ground mounts can be extended up to 15 feet above the roof line without requiring guy wires. Another advantage of telescoping masts is that they can be easily adjusted to odd heights without having to cut the tubing.

Because telescoping masts are heavy and require firm bottom support, they should not be used with

chimney or wall mounts. However, because ground and roof mounts do provide bottom support, telescoping masts can be used with these mounts to provide additional height.

For extra strength when installing large antennas, use a telescoping mast that is one size larger than actually needed. This will permit you to attach the antenna to the mast section immediately below the topmost one. This section is larger and stronger than the topmost section because it is reinforced by the 1-1/4" diameter section that remains inside.

When installing telescoping masts 20 feet or shorter in length, lay the mast on the ground and extend it to the desired length. Prop up the small end on a stable support and attach the antenna and transmission line. Then connect the bottom of the mast to the base mount and walk up the mast to its vertical position. (Use a base mount that will swivel!)

For masts over 20 feet long, securely mount and guy the bottom section first. Then attach guy rings and wires to the rest of the sections. Mount the antenna on the upper section, secure its guy ring and the transmission line. Using a person to hold the guy wires to each anchor point, raise each section one at a time, starting with the top. Tighten the wires after the mast is fully extended.



Fig. 4-14. A typical telescoping mast.

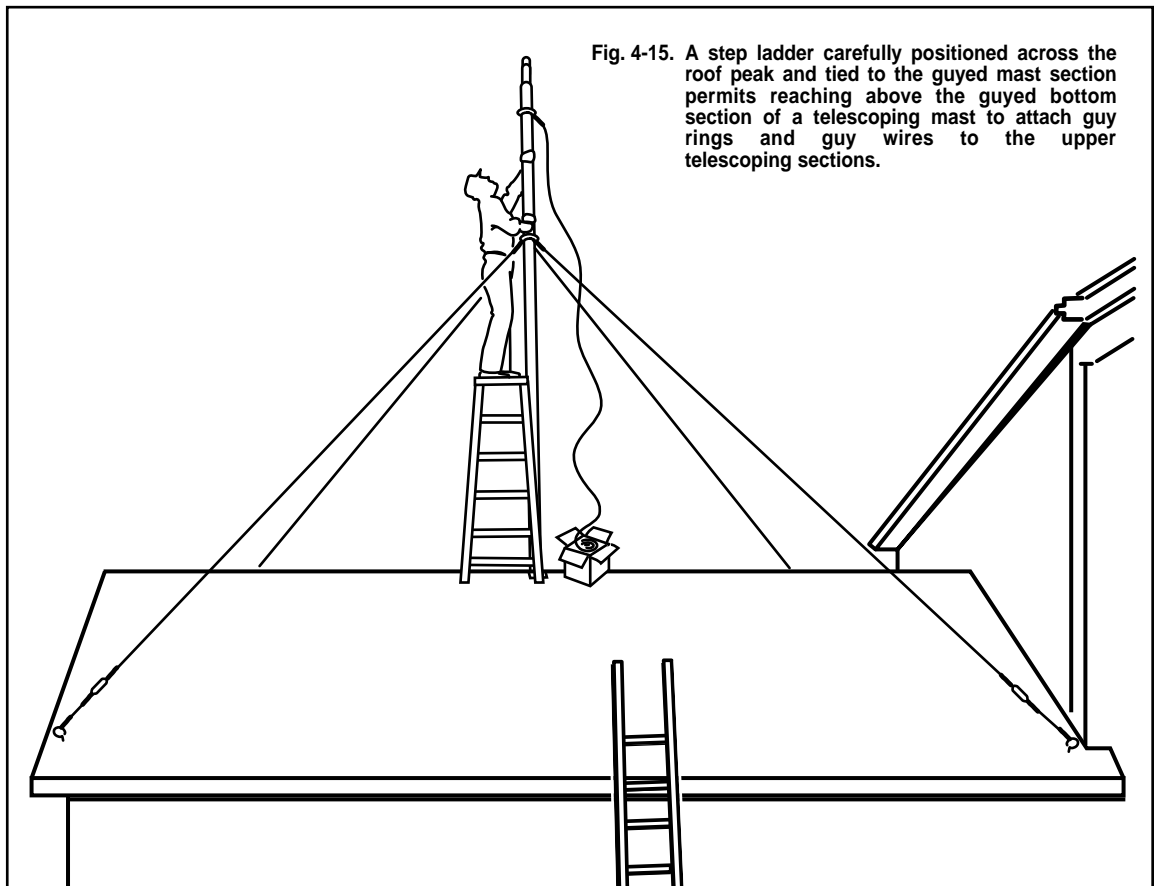

Fig. 4-15. A step ladder carefully positioned across the roof peak and tied to the guyed mast section permits reaching above the guyed bottom section of a telescoping mast to attach guy rings and guy wires to the upper telescoping sections.

Vent Pipe Mounting

Vent pipe mounting (Figure 4-16) secures the antenna and mast to the plumbing (gas) vent that comes up through the roof of the house. This type of mounting should be used only for the smallest antennas, and then only when economy absolutely demands it. Vent pipe mounts are not sturdy enough for medium and large antennas. Even a moderate wind or ice load may ruin the installation and damage your customer's property.

Standard vent pipe mounting hardware is available. However, it should be used with great care. Most vent pipes are made of soft materials like copper or orangeburg, which are easily crushed or dented by the stress exerted by the mounting bracket.

Towers

Antennas are mounted on towers (Figure 4-17) when exceptional height (35 feet or more) is required for adequate reception or when an unusually large antenna array must be used. Although they are very sturdy installations if properly installed, towers can be very difficult and dangerous to erect. Tower manufacturers' instructions and specifications usually include a large number of warnings and precautions that must be strictly followed. The best advice that can be given about tower installations before attempting one of your own, is to work with an experienced tower installer on one or more installations. If possible, have an experienced installer assist you with your first tower installation. If you do find yourself involved in a tower installation, be prepared for some heavy work and for the possibility of having to climb well above the height of the average roof.

If you must climb a tower, use an attachable work platform with a safety ring and safety belt. These are available from some tower manufacturers.

CAUTION: Before climbing any tower, first check the condition of the structure and the guy wires to make sure the installation is safe. Even a newly installed tower may have defects that make it dangerous to climb.

In most cases, a properly guyed 40 or 50 foot telescoping mast can be substituted for a 40 to 50 foot tower installation. It is not only easier and less dangerous to install, it is also significantly less expensive.

A detailed discussion about the various types of towers and the procedures for installing each of them would require more space than is available in this manual. The most accurate and helpful sources for such information is the extremely detailed instructions that most tower manufacturers provide with their towers.

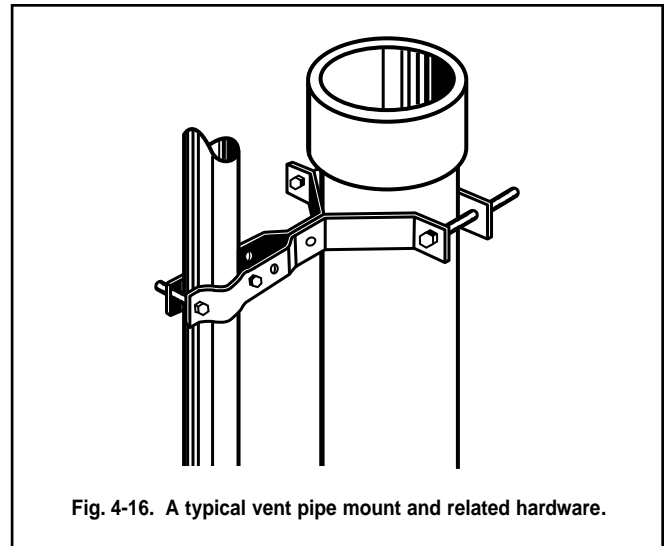

Fig. 4-16. A typical vent pipe mount and related hardware.

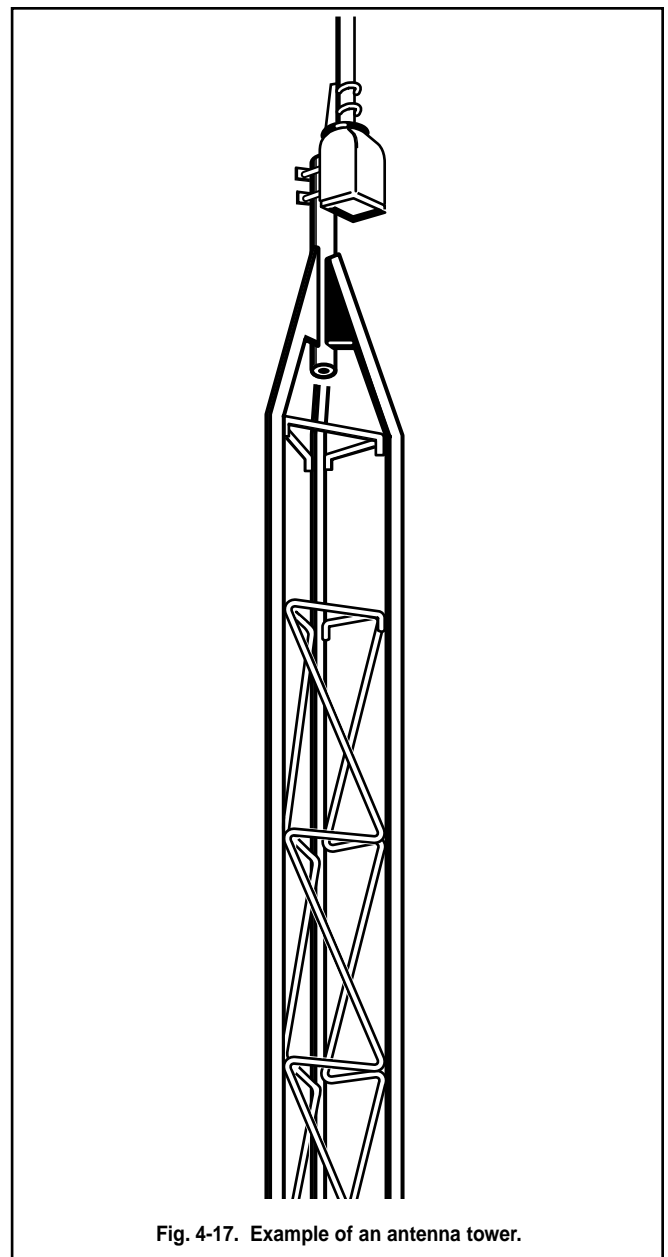

Fig. 4-17. Example of an antenna tower.

CHAPTER FIVE: SELECTING & INSTALLING TRANSMISSION LINE

Selecting and Installing Transmission Line

Transmission line or downlead, is the wire that carries the signal from the antenna output terminals to the receiver input terminals. Even the best antenna and the most expensive receiver will not produce an acceptable picture if the transmission line has not been carefully selected and correctly installed. The transmission line is more important than most people realize. Color television reception is sensitive and highly susceptible to interference from many different sources. Transmission line that is carefully chosen and neatly run by an installer who knows what he is doing will reward the customer with clear, distortion-free color TV reception.

The Two Basic Types

There are two basic types of transmission line: 300 ohm twinlead and 75 ohm coaxial cable.

Most antennas are 300 ohm balanced output. Therefore, an outdoor balun is required at the antenna in order to use 75 ohm coaxial cable. If a preamplifier with 300 ohm in put is used, a short length of 300 twinlead will be required between the antenna and preamplifier. Fig. 5-3 shows examples of baluns.

300 ohm twinlead (Figure 5-1) comes in various colors and thicknesses, is the least expensive, but requires more careful installation, and picks up interference signals if they are present. In modern installations, it is only used to connect between an antenna and a preamplifier.

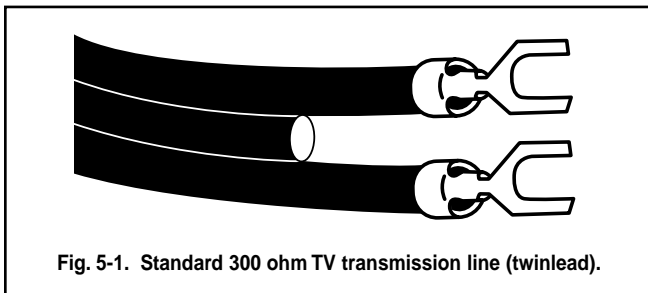

Fig. 5-1. Standard 300 ohm TV transmission line (twinlead).

Although more expensive, 75 ohm coaxial cable (Figure 5-2) is easier to correctly install, has a longer life, and does not pick up interference. Coaxial cable is round with a central conductor wire surrounded by plastic insulating material, a braided wire or aluminum foil sheathing, and a water-resistant outer covering jacket.

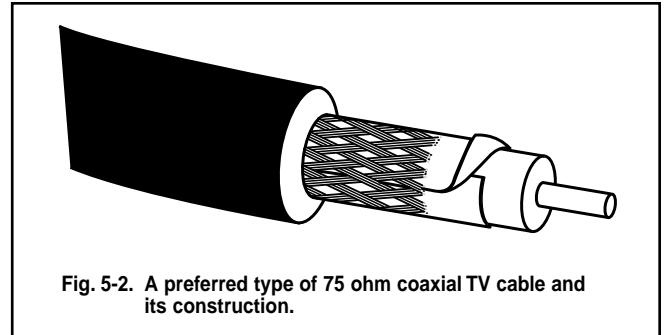

Fig. 5-2. A preferred type of 75 ohm coaxial TV cable and its construction.

Most modern TV sets have a single 75 ohm VHF/UHF input. Older TVs frequently have a 75 ohm VHF input and a 300 ohm UHF output. In this case, a band separator will be required. Coaxial cable has many advantages over twinlead and is preferred by most installers.

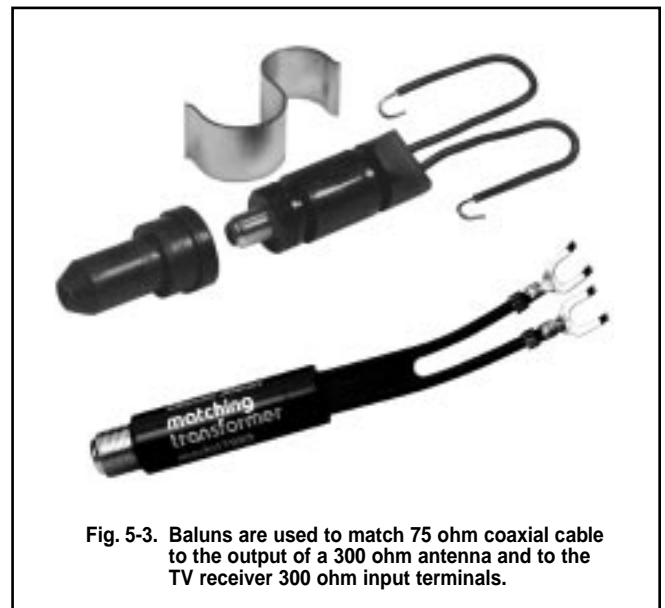

Fig. 5-3. Baluns are used to match 75 ohm coaxial cable to the output of a 300 ohm antenna and to the TV receiver 300 ohm input terminals.

Installing Twinlead

Start the twinlead installation at the antenna and work toward the receiver. First, assemble the antenna according to the manufacturer's instructions. Carefully "snap-out" the elements and then mount the antenna on the mast.

Attach the twinlead wire conductors to the antenna terminals with lugs. Never twist bare wire around the antenna terminals. It is a poor connection that will deteriorate even more as rust and corrosion set in.

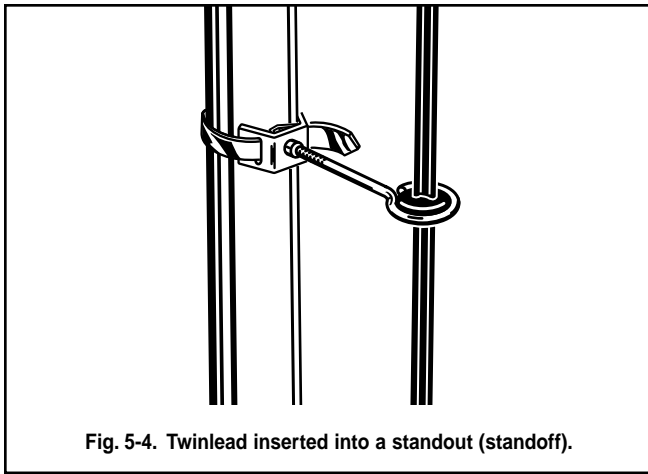

Fig. 5-4. Twinlead inserted into a standoff (standoff).

Next, pass the twinlead through a standout or standoff (Figure 5-4). Install the standout on either the mast or the antenna boom as recommended by the antenna manufacturer. Leave just enough slack to relieve tension on the antenna connections. Crimp the standout firmly enough to securely hold the twinlead but not so firmly that it deforms the twinlead.

Thoroughly spray the antenna connections with an acrylic insulator such as Krylon.

This will retard corrosion and rust. Also, seal the end of the twinlead if foam is used as part of the twinlead insulating material. This will prevent moisture absorption.

Twinlead must not be run close to metal. Metal interacts with the twinlead conductors. This causes signal mismatch, resulting in inefficient signal transmission through the line.

Horizontal runs of twinlead also act as an antenna. This causes two or more sets of identical signals to reach the receiver at different times producing ghosts on the TV screen. It may also cause "suck out," or loss of signal.

Some types of twinlead also develop high attenuation (increased impedance) in wet or humid weather. This causes severe signal loss.

If an antenna rotor is used, never run the twinlead and rotor wire through the same standout. The wires and signals will interact, and the quality of the TV picture will be decreased. Use two evenly spaced mast standouts for the top 5 feet of mast or in-line double standouts designed to carry both rotor and transmission line. Use additional standouts as necessary to keep the twinlead away from the mast. Standouts should be at least three inches long. Twist the twinlead once every three feet to prevent wind lashing (Figure 5-5).

Use additional standouts at ends and turns to keep the twinlead away from eaves, gutters, drainpipes and any other metal surfaces. When running twinlead

indoors, drive staples or tacks only in the center portion of the insulation between the conductors. Do not use any staples or tacks large enough to "bridge" the conductors. This will short the conductors. Run twinlead directly to the back of the set from the wall, floor, or baseboard. Don't leave more twinlead than absolutely needed. Extra twinlead will coil up and act as additional antennas. This causes ghosting and signal loss.

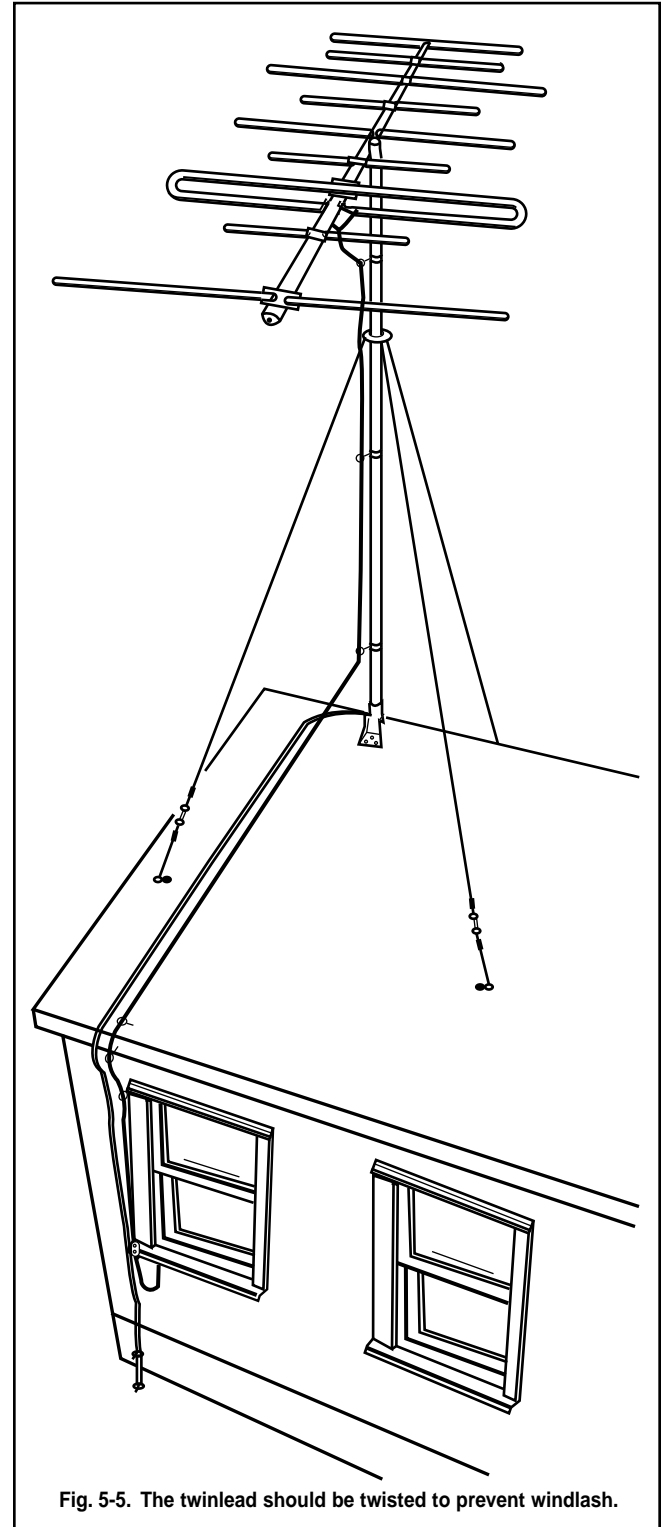
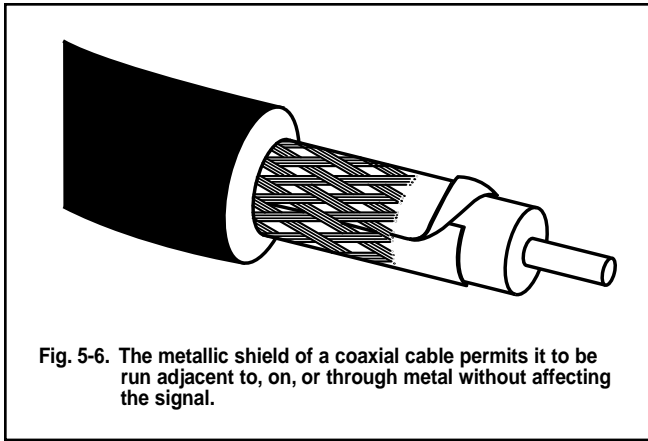

Fig. 5-5. The twinlead should be twisted to prevent windlash.



Installing Coaxial Cable

Because 75 ohm coaxial cable is shielded (Figure 5-6), it is completely unaffected by contact with metal structures, and it will not pick up unwanted signals as twinlead does. Also, its performance is not affected by moisture, and it generally has a much longer life span than 300 ohm twinlead.

Aluminum/mylar-equipped coaxial TV cable provides superior low-loss performance. (Examples are Channel Master coaxial cable model numbers 9533, 9539, 9540, and 9544.)

Begin installing coaxial cable by first connecting the "antenna end" to a balun. (The balun is not necessary if the antenna is one of the few with a 75 ohm output.) Attach the input lugs of the balun to the antenna terminals. Apply acrylic insulator or silicone grease to the connections. A weather boot (Figure 5-7) should also be installed over the connections.

Next, run the coax through a standout mounted on the boom or the mast. This will prevent the weight of the transmission line from creating stress on the antenna connections. From this point on however, the coax may be taped to the mast at appropriate intervals. Use plenty of good-quality vinyl tape to secure it. (If you also are installing a rotor, sufficient slack must be left in the transmission line between the mast and the antenna to permit rotation of the antenna. Also, coax and rotor wire can be run together without interaction or signal distortion. See Chapter 22 for details about rotor installation.

These are precautions that must be observed when installing coax:

1. Do not bend coax too sharply. This may collapse the dielectric and ruin the necessary spacing between the center conductor and shield.

2. Do not crush or deform the coax. Ghosting and smears may result.
3. When attaching connectors to coax, do not nick the center conductor. This will cause a stress point that will probably break the next time the wire is flexed.
4. Remember that in almost all cases baluns are required to match the 75 ohm coax impedance to the 300 ohm impedances of the antenna output and the TV input.

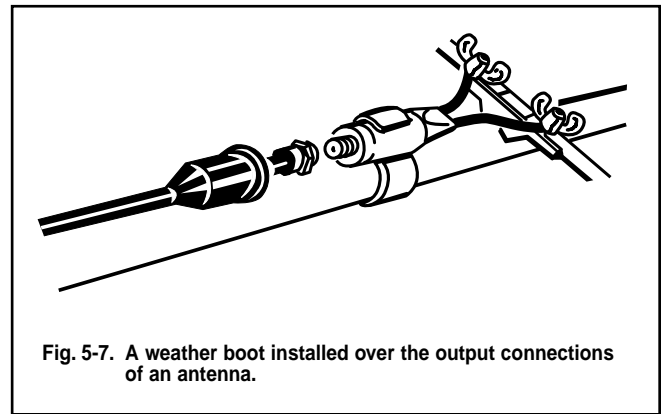

GENERAL GUIDELINES FOR INSTALLING TRANSMISSION LINE

Both coax and twinlead should be run as directly as possible to the receiver. Avoid excessively sharp bends or turns. You should also try to use one continuous transmission line without splices. (However, if necessary, two lengths of coax can be joined with a splicing connector (Figure 5-9). Also, keep the line away from anything with sharp or jagged edges.



Run the transmission line into the house through an attic or basement section if possible. Never run the line through a window or door. This invites damage to the line and is the mark of a careless installer.

If your entry is through shingles or shakes, remove one of the shingles and drill a hole for the line through the wall. Use a brace with an extension bit to drill through the insulation, plaster, and/or drywall. After you run the line through the hole, replace the shingle, and you'll have a neat, waterproof entry.

Note: Always make a drip loop (Figure 5-9) at the entry point so that water will run off the line and not into the house.

If you are running the line through wooden siding, drill a hole through the wall, run the line through and then seal the entry point with caulking compound for weather protection.

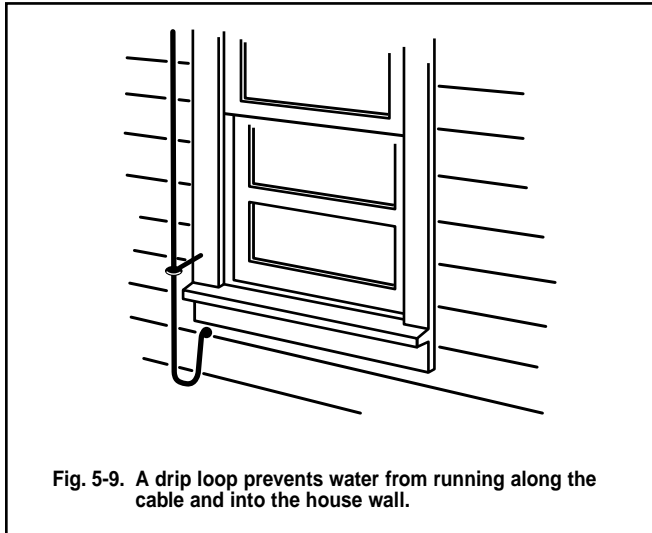

Fig. 5-9. A drip loop prevents water from running along the cable and into the house wall.

For an entry through brick, concrete, or stucco, use a hammer and star bit or a carbide-tip masonry drill bit. Again, caulking should be used to weatherproof the entry.

CAUTION: Before making an entry hole, always carefully check the interior surface of the wall for electrical fixtures or wiring that may be in the path of the drill bit. Do not enter near electrical wires or outlets especially when using twinlead.

Indoor runs of transmission line should be concealed as much as possible. With twinlead this is a practical necessity because it should be shielded from unwanted signals whenever possible. Coax should be concealed too, but mostly for neatness. If possible, run the line in closets, behind walls, behind baseboards and moldings, or up through the floor from the basement. Snaking the line down between wall studs however, is difficult and time consuming. Consequently, it shouldn't be done unless the customer has demanded it and has agreed to pay the extra cost. Before attempting to conceal the line behind baseboards and moldings, be sure that you can replace them exactly as they were without damage.

There are various couplers, amplifiers, and wall outlets that are useful in many installations. Because these devices usually come with detailed instructions, their installation will not be described in detail here. However, we suggest the following general procedures and guidelines:

1. Use only plastic outlet boxes or plaster straps for 300 ohm twinlead.
2. Locate TV outlets near electrical outlets. However, avoid running twinlead parallel to the electrical wiring in the wall. (Coax is not affected by the electrical wiring because it is shielded.)
3. When running transmission line from a coupler or amplifier, be sure it runs to the outlet(s) as directly as possible. The shorter the run the better.
4. Twinlead lines running in and out of any device should never be run close or parallel to each other.
5. If you must use twinlead outdoors, select the kind with a black polyethylene jacket. The sun's ultra-violet rays will not penetrate it, and it will not crack or chip in extreme heat.

Choosing the correct type and best quality of transmission line and then installing it correctly, is one of the keys to a customer-pleasing TV antenna installation. Don't skimp on quality. "Cheap" transmission line can be very costly in the long run. Most so-called "cheap" lines not only produce excessive attenuation and poor impedance matching, but also are made of poor grade polyethylene which deteriorates rapidly. This makes it necessary to replace an installation within a relatively short time. Because the dollar difference between "cheap" and quality line is minimal, it always pays to invest in the best.

CHAPTER SIX: GROUNDING PROCEDURES

The National Electrical Code (NEC) requires that every antenna installation be grounded. Also many areas have local antenna-grounding codes. Be sure that you are familiar with all of the grounding and other antenna regulations in your area.

Grounding an antenna is not just the law, it is good common sense. Because the antenna is usually the highest point on the house, it is highly susceptible to lightning strikes.

Grounding the Mast

The NEC requires that the antenna mast and mount be grounded directly. No splices or connections are allowed in the ground wire between the mast and the ground rod.

First, attach one end of a No. 8 or No. 10 copper or aluminum ground wire to the antenna mast (Figure 6-1). One of the bolts on the mount can be used as a fastening point. Masts that are painted or coated must have their coating scraped off around the area where they contact the mount. This will ensure an electrical connection between the mast and the mount. It is vital to get a good, solid connection. (Once the mast is attached to the mount, any scraped off portion that is exposed should be recoated with paint or other sealant.)

Next, run the ground wire to ground as directly as possible. Standard wire staples can be used to secure the ground wire against the side of the house. Avoid making 90° or sharper turns with the ground wire. A lightning charge has difficulty making such a turn and therefore may discharge into the house. Make ground wire bends as smooth and as gradual as possible.

The ground wire must be connected to a ground rod (Figure 6-2). Water pipes or plumbing fixtures are not acceptable. A good copper-coated steel ground rod driven at least 3 feet into the ground is required. Special clamps that provide a solid connection between the ground wire and ground rod should be used.

Grounding the Transmission Line

It is not just the height of an antenna that makes it susceptible to lightning strikes. Antennas and transmission line can accumulate static electrical charges that also increase the chances of lightning hitting an installation. To properly “draw off” this static electricity, a small device known as an antenna discharge unit (Figure 6-3) must be included on the installation. The antenna discharge unit (also called a “lightning arrester”) is connected to the transmission line at a point close to where the transmission line enters the

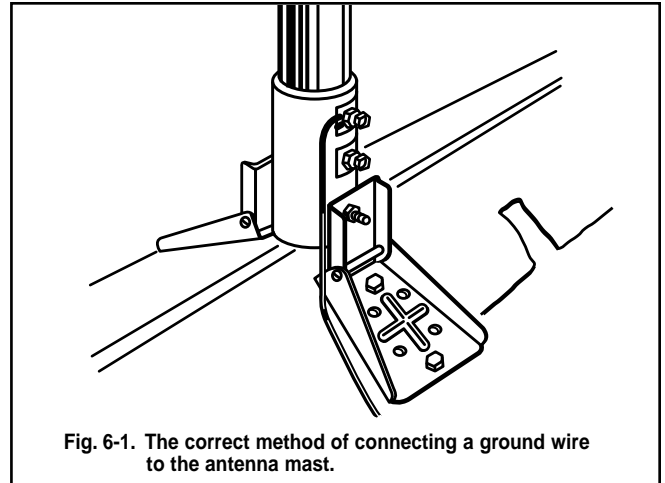

Fig. 6-1. The correct method of connecting a ground wire to the antenna mast.

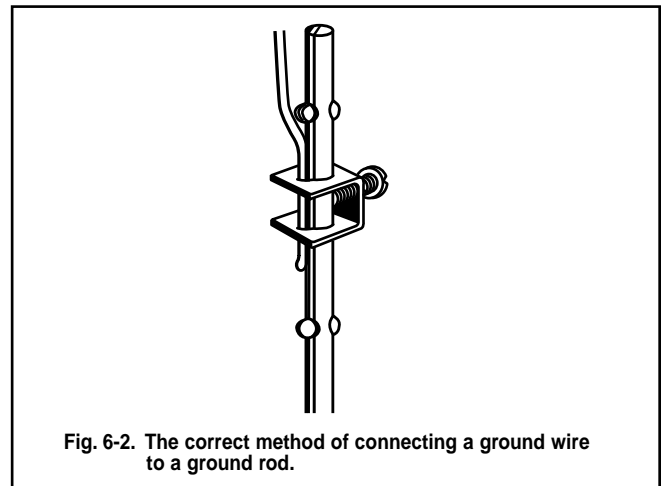

Fig. 6-2. The correct method of connecting a ground wire to a ground rod.

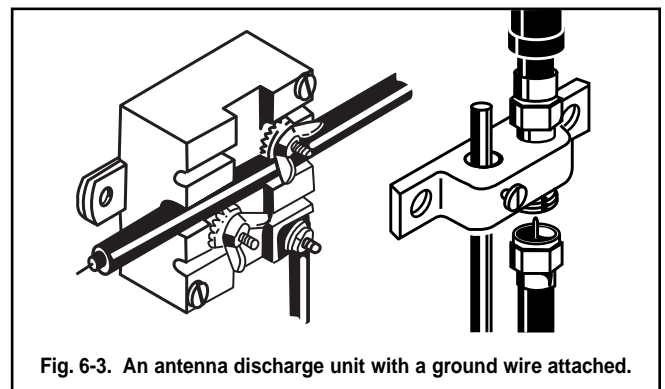

Fig. 6-3. An antenna discharge unit with a ground wire attached.

house. One end of a ground wire is attached to the discharge unit. The other end of the wire is connected directly to the ground rod.

Installation of the antenna discharge unit is very easy, and detailed instructions come with each unit.

An antenna installation is not adequately grounded unless both a mast ground and an antenna discharge unit are installed correctly.

CHAPTER SEVEN: SELECTING & INSTALLING GUY WIRES

Consistent, safe support of antenna installations over 10 feet above the uppermost wall bracket or roof mount depend on how well the guy wires are installed. The correct installation procedure is relatively simple. However, only the best quality materials and careful installation will provide sturdy, safe, long-lasting support.



Fig. 7-1. The materials and hardware needed for guying a standard three-wired guyed installation.

Guy Wire Installation

The materials needed for a standard guy wire installation are: guy wires, a guy ring(s), screw eye, and turnbuckles (Figure 7-1). Six-strand, 18 or 20 gauge galvanized steel guy wire is recommended for general use. (The 18 gauge wire is recommended for high-wind areas and installations over 20 ft. above the uppermost support.)

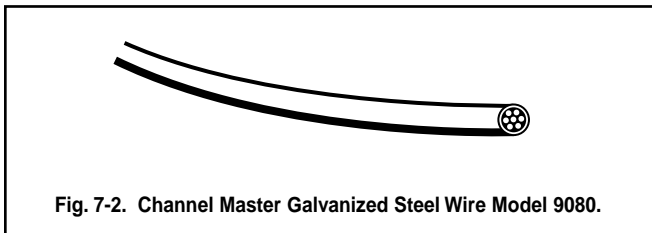

Fig. 7-2. Channel Master Galvanized Steel Wire Model 9080.

Standard antenna masts (10 feet in height) require only one set of three guy wires (Figure 7-3). Telescoping masts generally require 4 guy wires for each 10 foot section. This will give the extra strength required for most installations.

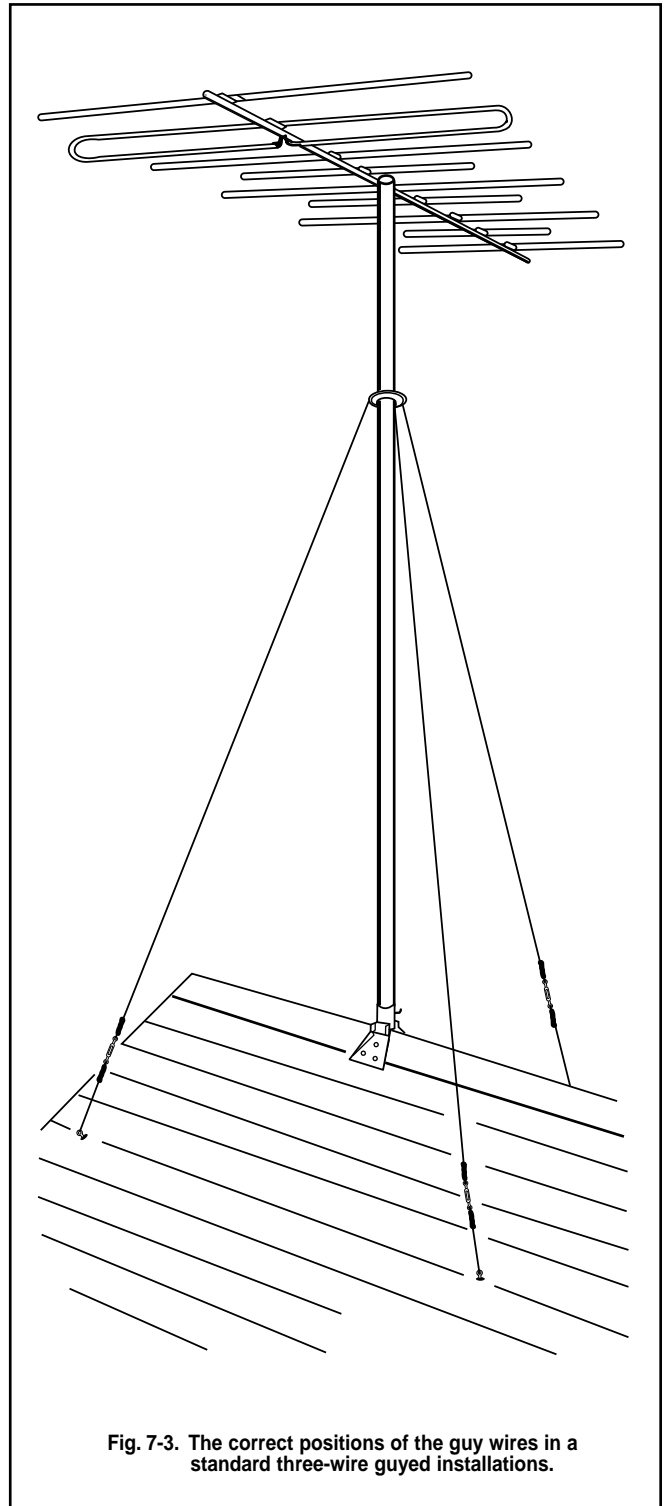
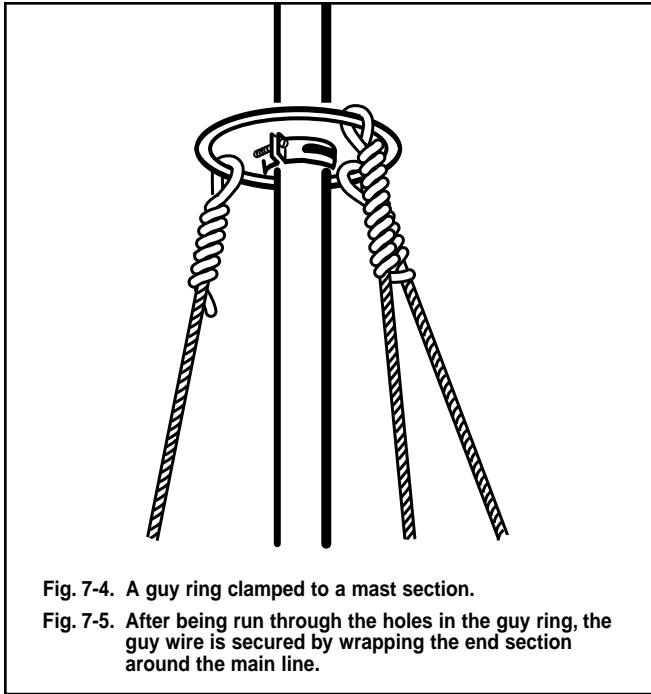
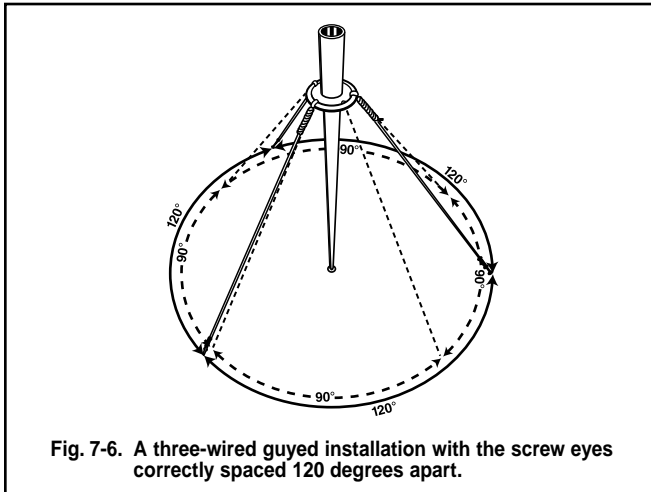

Fig. 7-3. The correct positions of the guy wires in a standard three-wire guyed installations.

The guy wires are attached to the upper half of each mast section with guy ring and clamp. The ring and clamp are fitted to the mast before the antenna is attached (Figure 7-4). The mast ends of the guy wires are run through holes in the guy ring. The wire then is wrapped around itself at least six times (Figure 7-5).



Ideally, the guy wires should extend out from the mast at a 45° angle, and should be anchored in screw eyes placed 120° apart (Figure 7-6). (If four guy wires are used, they should be anchored in screw eyes 90° apart.) Be sure each screw eye is firmly anchored in solid wood at least five feet from the base of the mast. After the guy wires are installed, cover each screw eye with roofing tar.



Attach fully-extended turnbuckles to guy wires about a foot from each screw eye (Figure 7-7). Run the screw eye ends of the wires through the eyes and pull the wires equally taut. (Be sure the mast remains vertical during this procedure.) Wrap each wire around itself at least six times.

The final tightening of the guy wires is accomplished by rotating the turnbuckles with a screwdriver. Do not make the wires too tight; the installation must “give” a little against wind force.

If the installation requires more than one set of guy wires, use separate screw eyes for each wire. A single screw eye may not be anchored solidly enough to hold two or more guy wires. A good quality screw eye should be used, and it should be at least 5” long and 5/16” in diameter. For guying a tall ground-mounted mast, use heavy-duty ground stakes.

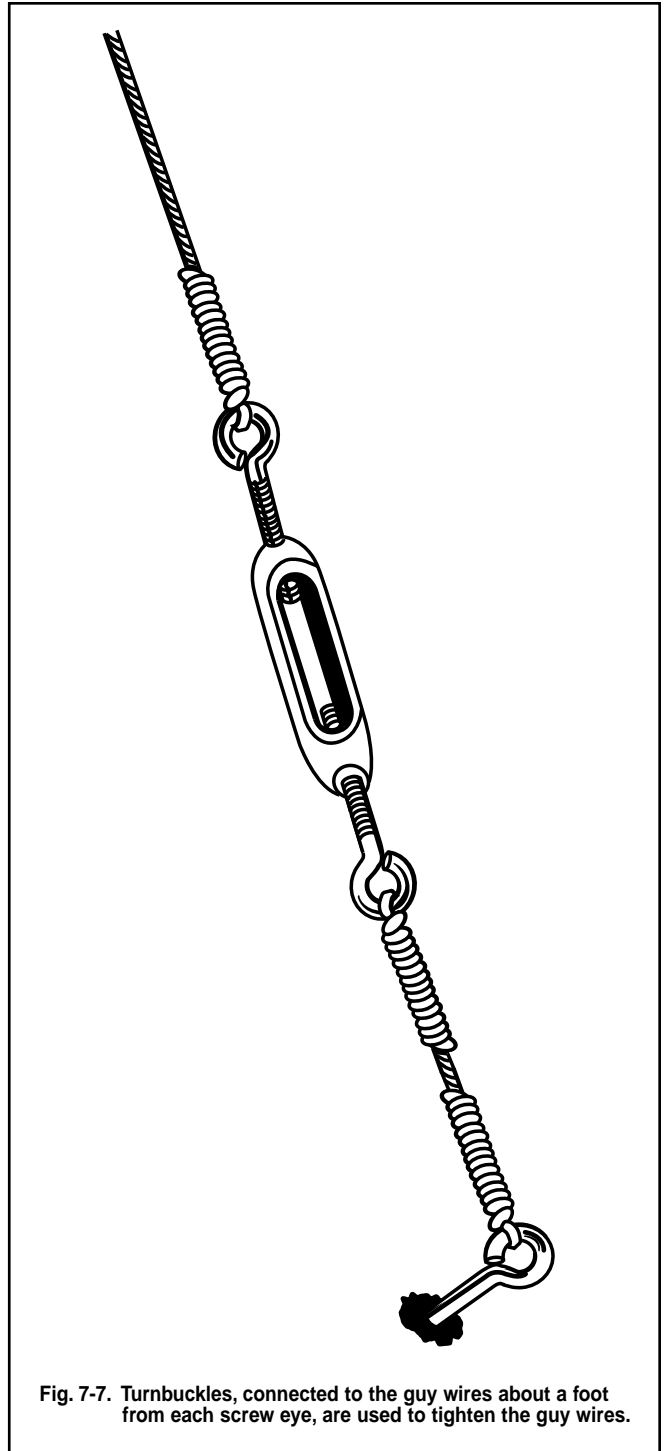

CHAPTER EIGHT: ANTENNA ROTORS

A rotor or rotator is a mast-mounted, motor-driven device (Figure 8-1) that permits the TV viewer to conveniently rotate (orient) the outdoor TV antenna in any direction. It is started and stopped by a manually operated control unit (Figure 8-2) that is placed indoors near the TV set. A multi-conductor wire carries the power and control signals from the indoor control unit to the mast-mounted drive unit.



Fig. 8-1. The mast-mounted drive unit of an antenna rotor.

A rotor should be considered when the desired TV signals arrive at the receiving site from widely spaced directions that cannot be accommodated by the relatively narrow beamwidth of a single, fixed-position antenna. With a rotor, a viewer can conveniently orient the antenna in the direction of the desired channel's transmitting tower, or in the direction that provides optimum reception of a particular channel. A rotor also permits convenient "fine tuning" of the antenna direction to compensate for variations in signal direction caused by changing atmospheric conditions or other signal-distracting conditions. Additionally, the rotor permits elimination of adjacent-channel and other types of interference that in some cases, can be solved by slight reorientation of the antenna.

Automatic Rotors

The control unit of the automatic type rotor (Figure 8-2) has a direction-calibrated knob (or dial). When this knob is turned to the desired compass direction, the drive unit automatically turns the antenna to that direction and then stops it.

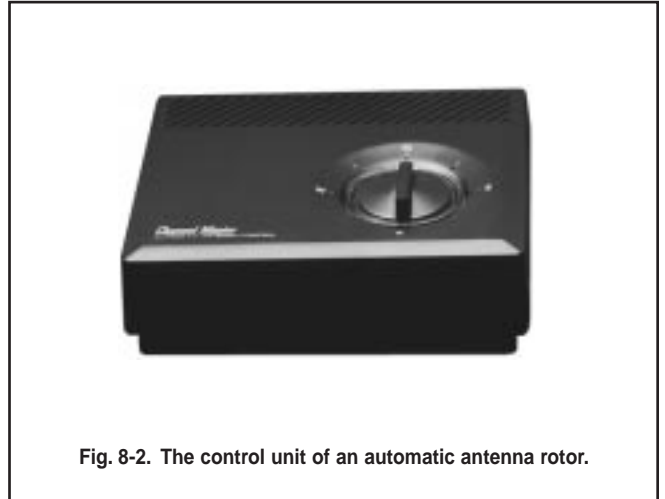

Fig. 8-2. The control unit of an automatic antenna rotor.

Installing the Rotor

To install a rotor, first assemble the antenna and attach it to a short section of mast. (This short mast section later will be installed in the top part of the drive unit.) If the antenna is large and has boom braces, the short mast section must be long enough to accommodate the boom braces and possibly a rotor alignment bearing. A 3-1/2 foot section should be long enough. Use a shorter section if the antenna is small.

Attach the transmission line to the antenna, and set aside the antenna and mast.

Remove the bottom (or access plate) of the drive unit housing and attach the rotor wire (Figure 8-3). (Rotor wire is available in many different styles; however, the most practical and economical kind has only three conductors. An example is Channel Master Rotor Wire Model No. 9554.) All Channel Master antenna rotors use 3 conductor rotor wire. To attach the rotor wire to the drive unit, first strip back the insulation on all conductors and solidly twist together the wire strands that make up each conductor. Be sure there are no loose strands; they may impair the performance of, or short out the rotor. Use connecting lugs to attach the wires to the rotor terminals.

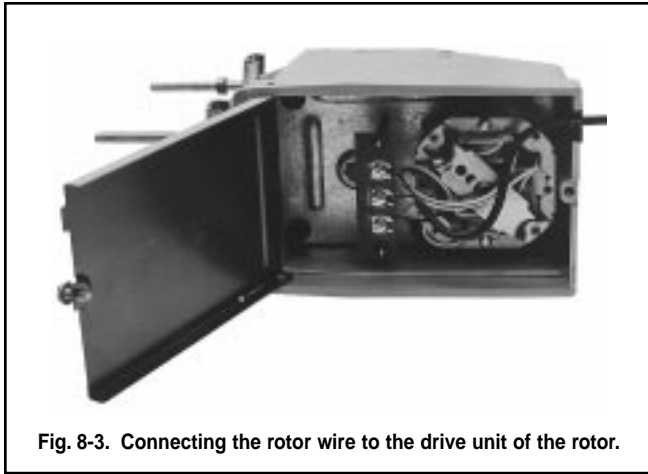

Fig. 8-3. Connecting the rotor wire to the drive unit of the rotor.

The “reference wire” is either wider or is a different color than the other conductors. Connect it to terminal No. 1. Connect the middle wire to terminal No. 2, and the third wire to terminal No. 3. If you use four or five-conductor wire, attach the third, fourth, and fifth wires to terminal No. 3. (Figure 8-3 shows the rotor wire connections to the drive unit.)

The wires must not touch each other or the housing after they are connected. Cover each connection with an insulating material to prevent corrosion and rusting. Then reinstall the bottom (or access plate) of the housing.

Next, attach the drive unit to the main mast. After this is done, insert the short mast (with the antenna attached) into the top of the drive unit (Figure 8-4).

An alignment bearing (Figure 8-5) is absolutely necessary for large antennas or arrays to prevent excessive pressure on the drive unit. If you are installing a rotor alignment bearing, the main mast must extend far enough above the drive unit to hold the bearing in place (Figure 8-6).

An antenna (or array) large enough to require an alignment bearing should also be guyed above the level of the drive unit. Most alignment bearings have “eyes” for attachment of guy wires. A separate ball bearing guy ring should be used with an alignment bearing that does not have eyes for guy wires. It is attached to the mast above the alignment bearing. If the rotating mast is exceptionally long, use a ball bearing guy ring in addition to the guyed alignment bearing.

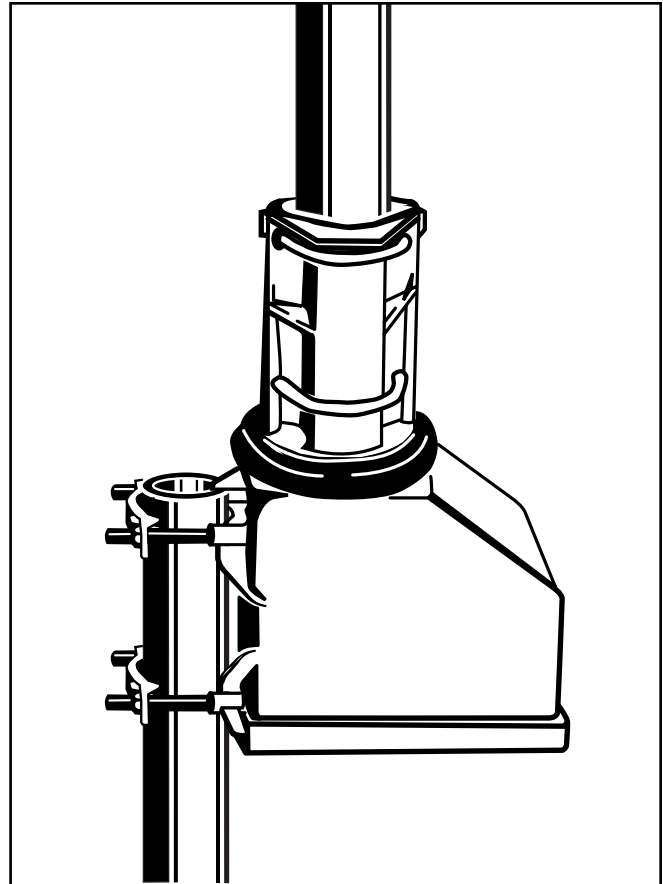

Fig. 8-4. The bottom (stationary) part of the drive unit is connected to the top of the main mast section. A short mast section then is installed in the top (rotatable) part of the drive unit.

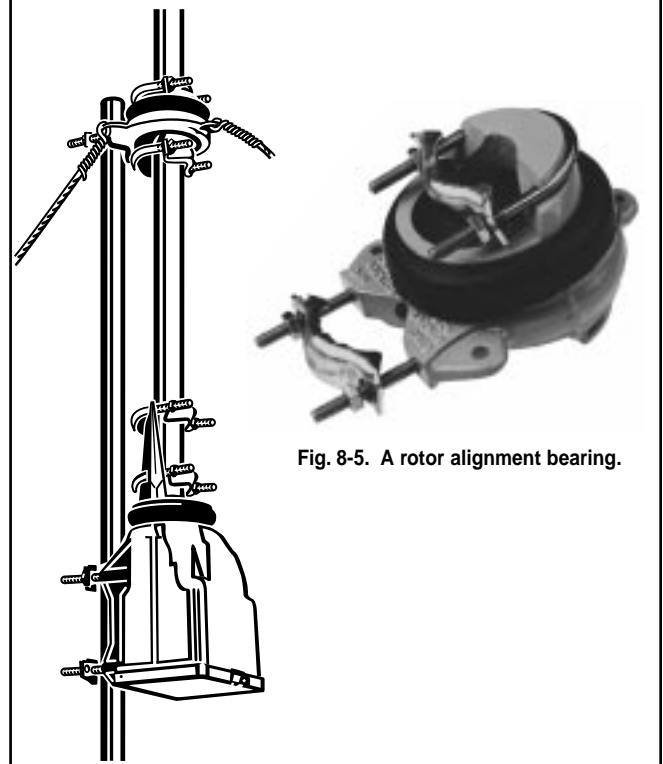

Fig. 8-5. A rotor alignment bearing.

Fig. 8-6. A correctly installed rotor alignment bearing.

As previously mentioned, a loop of transmission wire must be left between the antenna and the drive unit to prevent the line from becoming tangled in the antenna or otherwise restricting rotation. Be sure the housing of the rotor drive unit is properly aligned with the antenna terminals. To properly align the rotor with the antenna, always install the drive unit with the front (the side of the unit without fixtures), facing away from the antenna terminals (Figure 8-8). This will allow the transmission line to be looped into a snap-on standout approximately 3"-4" below the rotor on the rear of the drive unit housing (the side with clamps for the main lower mast).

When the rotor and antenna have been properly aligned, tighten the clamps holding the top (antenna) mast and run the rotor wire down the main mast. The best way to do this is to use 7" standouts or in-line double standout; (for transmission line and rotor wire) mounted with nutbuckle and strap, spaced equal intervals along the main mast. (Taping the rotor wire to the mast may be acceptable for some smaller installations.)

Coaxial cable should be used with all rotor installations to void interaction that can occur between rotor wire and 300 ohm twinlead. If you must use twinlead, keep it at least 3" away from the rotor wire and mat at all times. Again, the use of in-line double standouts before the rotor (Figure 8-9) is recommended.

The rotor wire should be connected to the control units in the same manner as it was connected to the drive unit. The reference wire is connected to terminal No. 1, the middle wire to terminal No. 2, and the third wire to terminal No. 3. Leave enough rotor wire at the control unit to permit movement of the unit to any point in the room.

The final step in a rotor installation is to synchronize the control unit with the drive unit. For fully automatic control units, turn the control dial (knob) clockwise to the due north setting and allow the antenna to rotate until the control unit stops it. Then, turn the dial counterclockwise to due north, again allowing the antenna to rotate until the control unit stops it. The installation is now synchronized.

The process is the same for semi-automatic control units except that you must depress the clockwise and counterclockwise buttons one at a time until the antenna stops at north in both rotational directions. Anytime you believe the installation is out of synchronization, repeat the above process.



Fig. 8-7. A loop of extra transmission line must be left between the antenna and the drive unit to prevent the line from tangling in the antenna or otherwise restricting its rotation.

Fig. 8-8. Always install the drive unit with the "front" facing away from the antenna output terminals.

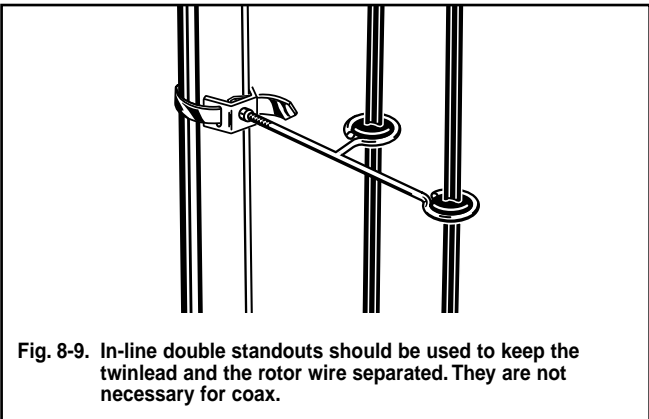

Fig. 8-9. In-line double standouts should be used to keep the twinlead and the rotor wire separated. They are not necessary for coax.

Control units come with small adhesive stickers that can be placed on the control unit housing to indicate the best antenna position for each channel. When you have determined the best antenna position for a channel, place a sticker with the channel number in the appropriate spot on the control unit housing. The rotor installation is now complete.

CHAPTER NINE: ANTENNA-MOUNTED AMPLIFIERS

A mast or antenna-mounted amplifier (preamp) is used primarily to eliminate “snow” on the TV screen. “Snow” (Figure 9-1) is actually electrical noise that is generated by the TV receiver and other electrical devices. The object of any installation is to deliver to the TV input terminals, signals that are strong enough to override the noise (snow). Traditionally a “weak” signal is defined as one that is not strong enough to override the level of the noise in the receiver.



Fig. 9-1. Weak signals cause “snow” on the TV screen.

When to Use a Preamp

There is no simple or universal rule that tells you when to install an antenna-mounted preamp (Figure 9-2). Generally if the level of the received signal is less than 1,000 μV at the receiver input terminals, preamplification is needed.

Customer preference is another factor that must be weighed when considering the use of a preamp. Some customers may not agree to the added expense of a preamp and will be content with a picture that is less than perfect. Others may insist on a preamp just because they want only the best.

Aside from customer preference, there are many other variables that will influence your decision. For example, a preamp generates a small amount of noise. In areas with extremely weak signals, even the low level of noise in the preamp will be too near the level of the received signal. Because both the received signal and the noise are amplified an equal amount, the difference in their relative levels will never be great enough to permit the received signal to override the noise and eliminate the snow on the screen. Consequently, you might want to consider another method of boosting a very weak signal.

Vertically stacking two antennas and pointing them in the same direction is probably the best alternative to a preamp. This will provide additional gain without

introducing more noise. However, this will not always solve the problem especially if the received signal is exceptionally weak.

In extremely deep fringe or otherwise difficult reception areas, you might have to use both antenna stacking and a preamp. However, this is very rare.

Selecting a Preamp

A major consideration when selecting a preamp is the possible sources of interference in the area. It is vital that as an installer, you become familiar with the commercial broadcast and other radio frequency signals that are being used in your area. Local FM stations, police and fire frequencies, military communications, and other sources of radio frequency signals can cause interference that should be trapped (filtered out) at the preamp stage.

For this reason, preamps are available with almost every conceivable arrangement of traps (filters). Tunable traps can be adjusted to eliminate a specific frequency, while switchable traps attenuate (reduce the level of) an entire band of radio frequency signals. If an installation is experiencing severe interference from one local station (located at 101.5 MHz for example), a tunable trap can be adjusted so that any signals at this frequency are eliminated without attenuating the rest of the FM band. If interference is caused by several FM stations, you will have to use a switchable trap that attenuates the entire FM band.

Many customers want to receive both TV and FM signals from one antenna. Adding a trap to a preamp will not necessarily make this impossible. In general, any FM signal strong enough to require trapping will also be strong enough to be picked up by an FM receiver even though it is trapped out of the TV bands. (An FM receiver requires a much lower level of signal to operate well than does a TV.) When a switchable trap is used however, some of the weaker, more distant FM stations will be lost.

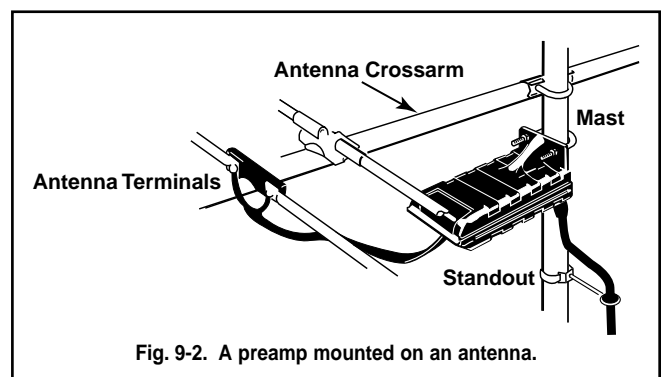

Fig. 9-2. A preamp mounted on an antenna.

Although the ideal preamp usually is the one with the lowest noise figure and the highest gain, compromises sometimes must be made. If very strong local signals are present, a preamp with a high input capability must be used. A high input capability will prevent the strong local signals from overloading the preamp. However, a preamp with a high input capability has a slightly higher noise figure.

Coaxial cable should be used with all preamp installations. Coax is much less likely to introduce additional signal problems.

Tunable traps should be adjusted before they are installed. It is easier to adjust them on the workbench than to try to tune them after they are on the antenna. Simply hook up the preamp with the trap to the input of a field-strength meter, or to the antenna terminals of an FM radio if the trap is designed to attenuate FM signals. Tune the meter (or radio) to the frequency (or station) to be trapped out and then adjust the trap to the point at which the unwanted signal is attenuated, as indicated by a reduction in the sound level.

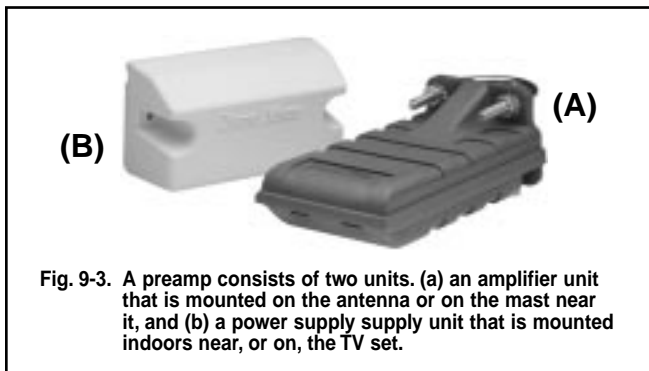

Fig. 9-3. A preamp consists of two units. (a) an amplifier unit that is mounted on the antenna or on the mast near it, and (b) a power supply unit that is mounted indoors near, or on, the TV set.

Installing a Preamp

A preamp consists of two units: a preamp and a power supply (Figure 9-3). The preamp itself is mounted on the antenna boom or on the mast as close to the antenna as possible. The power supply unit is mounted indoors. Power is supplied to the preamp unit through the transmission line.

The preamp is located as close as possible to the antenna feedpoint because the weak received signal must be amplified before it is attenuated by the transmission line, and also before it can be subjected to interference from sources between the antenna and the receiver. Preamps mounted farther from the antenna usually amplify (magnify) the interference along with the signal.

Preamp units come with U-bolts for easy mounting on the mast or the antenna boom. Antennas such as Channel Master QUANTUM® Models can accommodate a preamp within a special terminal housing (Figure 9-4).

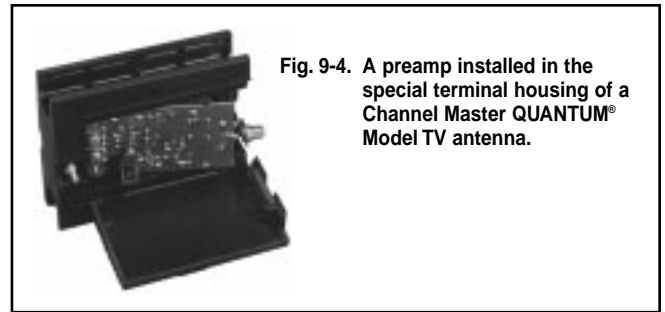

Fig. 9-4. A preamp installed in the special terminal housing of a Channel Master QUANTUM® Model TV antenna.

Note: Do not mount preamp to a "hot boom" antenna.

After the preamp is attached to the antenna or mast, run a length of 300 ohm transmission line from the antenna output terminals to the input terminals of the preamp.

Use the insulation-piercing terminals provided in the preamp. Leave enough slack in the transmission line to form a drain loop. This will keep water out of the amplifier housing. Coat the connections with an insulate sealant.

Next, run the transmission line from the output terminals of the preamp to the power supply.

Note: The transmission line also carries power to the amplifier. There is no separate power line to run.

The power supply unit is mounted indoors, usually near the TV set (Figure 9-5). You may want to mount it on the back of the TV. If you do, be careful not to block any of the ventilating holes on the rear panel of the set.

Most preamp power supply units have mounting holes that can be screwed to any relatively flat surface.

Connect the transmission line from the antenna to the input terminals on the power supply unit.

Next, run a length of transmission line from the power supply output terminals to the TV.

The last step is to plug in the power supply. Because it uses less current than an electric clock, it will not be expensive to leave it plugged in.

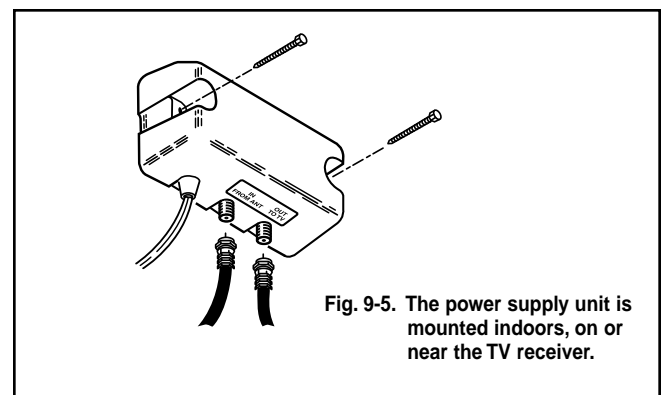

Fig. 9-5. The power supply unit is mounted indoors, on or near the TV receiver.

CHAPTER TEN: MULTI-SET RECEPTION

Many homes have more than one TV set. Others have at least one FM radio receiver and VCR. Consequently, the installer often must use an antenna system that feeds the received signals to two or more receivers. This is called multi-set reception.

Supplying the signal from one antenna to two or more receivers requires the use of special devices that prevent problem-causing interaction between the TV receivers. Without the devices, the interaction between receivers will reduce the quality of the pictures displayed by the receivers. Problems caused by such interaction include multiple images (ghosts) and loss of picture detail (smearing).

Passive Devices

One method of multi-set reception uses what are called passive devices. The term "passive" means that they do not amplify (increase) the strength of the signals. Passive devices prevent receiver interaction by "isolating" the TV receivers from each other. However, because passive devices cause reduction of signal strength, multi-set reception systems equipped with these devices require more signal strength out of the main transmission line than do antenna systems that feed only one TV set. Typical signal strengths required for multi-set reception vary from a minimum of 2000 microvolts (uV) to over 4000 microvolts depending on the number of passive devices used in the system.

There are two types of multi-set passive devices: couplers and splitters. Couplers are used in multi-set systems equipped with 300 ohm twinlead. Splitters are used in systems that are equipped with 75 ohm coaxial cable. Couplers and splitters perform the same basic function.

Most couplers are designed to distribute signals to either two or four sets. The coupler (Figure 10-1) usually is mounted on or near one of the TV sets, preferably one that is centrally located. Twinlead is run from the coupler's outputs to the antenna input terminals of the TV receivers.

Couplers are the most economical way of feeding two or more TV sets. However, because twinlead is used, couplers present all of the interference pickup and other installation problems associated with twinlead. Be careful where and how you mount couplers.

Most splitters (Figure 10-2) are also designed to feed either two or four TV sets. However, because they are designed for use with coaxial cable, splitters can be mounted just about anywhere without picking up interference or causing other problems that reduce picture quality.

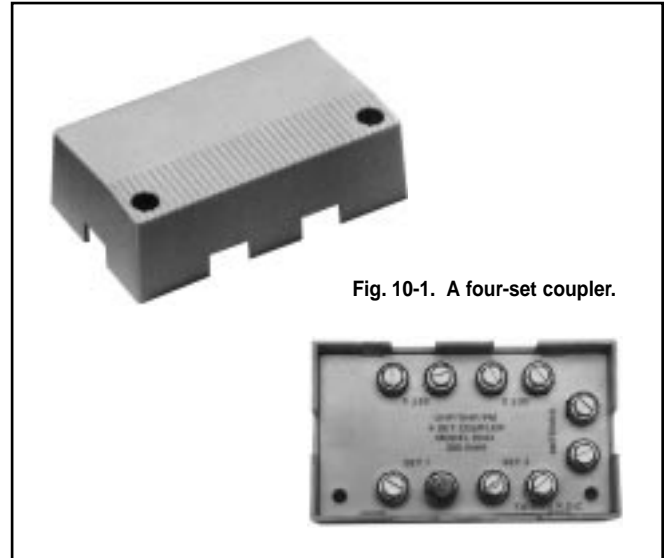

Fig. 10-1. A four-set coupler.

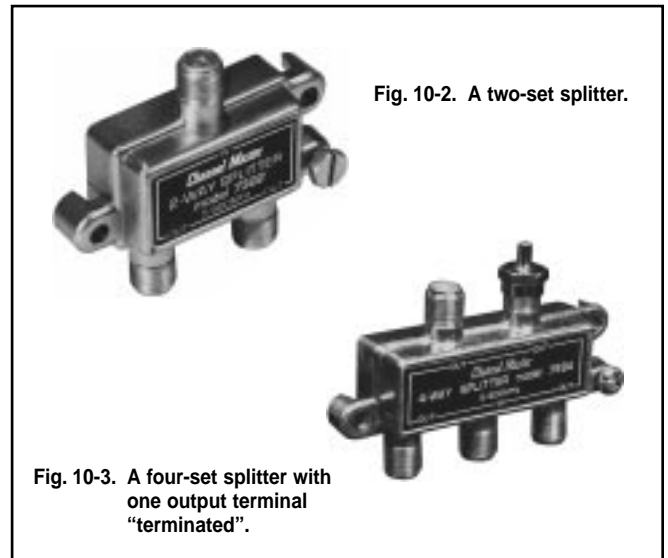

Fig. 10-2. A two-set splitter.

Fig. 10-3. A four-set splitter with one output terminal "terminated".

When a four-set splitter is used to feed only three receivers, the unused splitter output must be "terminated" to prevent signal problems. "Terminated" means that a small 75 ohm device (Figure 10-3) is connected to the unused output connection of the splitter. This is done to prevent the unused signal from "bouncing back" through the coax and interfering with the signals fed to the TV receivers. Terminating devices are available for use with most standard splitters.

Before attempting multi-set reception with passive devices, use a field-strength meter to measure the signal strength at the receiver end of the main transmission line. If it is less than 2000 microvolts (uV) and you need to feed three sets, you will have to increase the signal level. To do this, you will have to use one of the following methods:

- A higher gain antenna
- A mast-mounted preamplifier (preamp)
- Both a higher gain antenna and a preamp
- An Amplified Coupler

Amplifiers



Fig. 10-4a. Channel Master® Preamplifier.



Fig. 10-4b. When many outlets (more than 4) are required, a distribution amplifier should be used.

When signal levels are weak, a preamplifier (Figure 10-4a) should be used as this will give the lowest system noise figure. A distribution amplifier (Figure 10-4b) is a type of amplifier that is mounted indoors, usually in a central location. It is designed to provide amplified signals to a number of TV sets. The term “amplified” means that the strength of the signal is increased by electronic circuits called amplifiers. See the Channel Master catalog for models.

The distribution amplifier should be mounted in a relatively central location so that the coaxial cables (through which it feed signals to TV sets) are the same length. This will help ensure that all TV sets receive the same strength of signals.

In areas with very weak signals you will need to use both a mast-mounted preamp and a distribution amplifier. However, be sure the two amplifiers are matched. The term “matched” means that the electronic characteristics of the two amplifiers are similar enough to permit using them together without causing interaction and reducing picture quality. A signal-distribution system that is equipped with a matched pair of amplifiers is called a tandem system. The matched amplifiers are called “tandem units.” See the Channel Master catalog for models.

MATV Systems

“MATV” means Master Antenna Television (system). A home MATV system is an expanded version of the multi-set reception systems described previously. It is used to distribute the signals from one antenna (or antenna array) to a number of wall outlets located at convenient points in all or most rooms of the house.

The components and distribution network of a typical medium-size home MATV system are shown in Figure 10-5. The antenna signals are fed through coaxial cable to a distribution amplifier. This amplifier increases the strength of the signals and then splits them into two or more outputs. The signals at these outputs are fed through coaxial cable to conveniently located splitters. The splitters, in turn, divide the main branches into subbranches, which feed the wall outlets in one or two rooms. Coaxial cable is used throughout the system. Ideally, a home MATV system should be installed while the house is being built, so that the cables can be conveniently run inside the walls. However, a MATV system can also be installed in a finished house by feeding the cables into the wall spaces through holes drilled in the attic floor above the spaces. The cable-entry holes also can be drilled through the main floor from the basement or crawl space.

A home MATV system can be expanded to provide closed-circuit TV surveillance of various outdoor and indoor areas, including nurseries, playrooms, and house entrances. It also can be used to distribute Cable TV or Community Antenna Television (CATV) signals throughout the house.

MATV is relatively easy to install. Don’t hesitate to suggest MATV to your customers. Most probably do not know about MATV and the convenient, high-quality reception that it provides for a relatively small investment. You can substantially enhance your reputation and your profits by providing MATV sales, installation, and service to both homes and businesses. MATV for business is no more difficult to plan and install than that used in large houses.

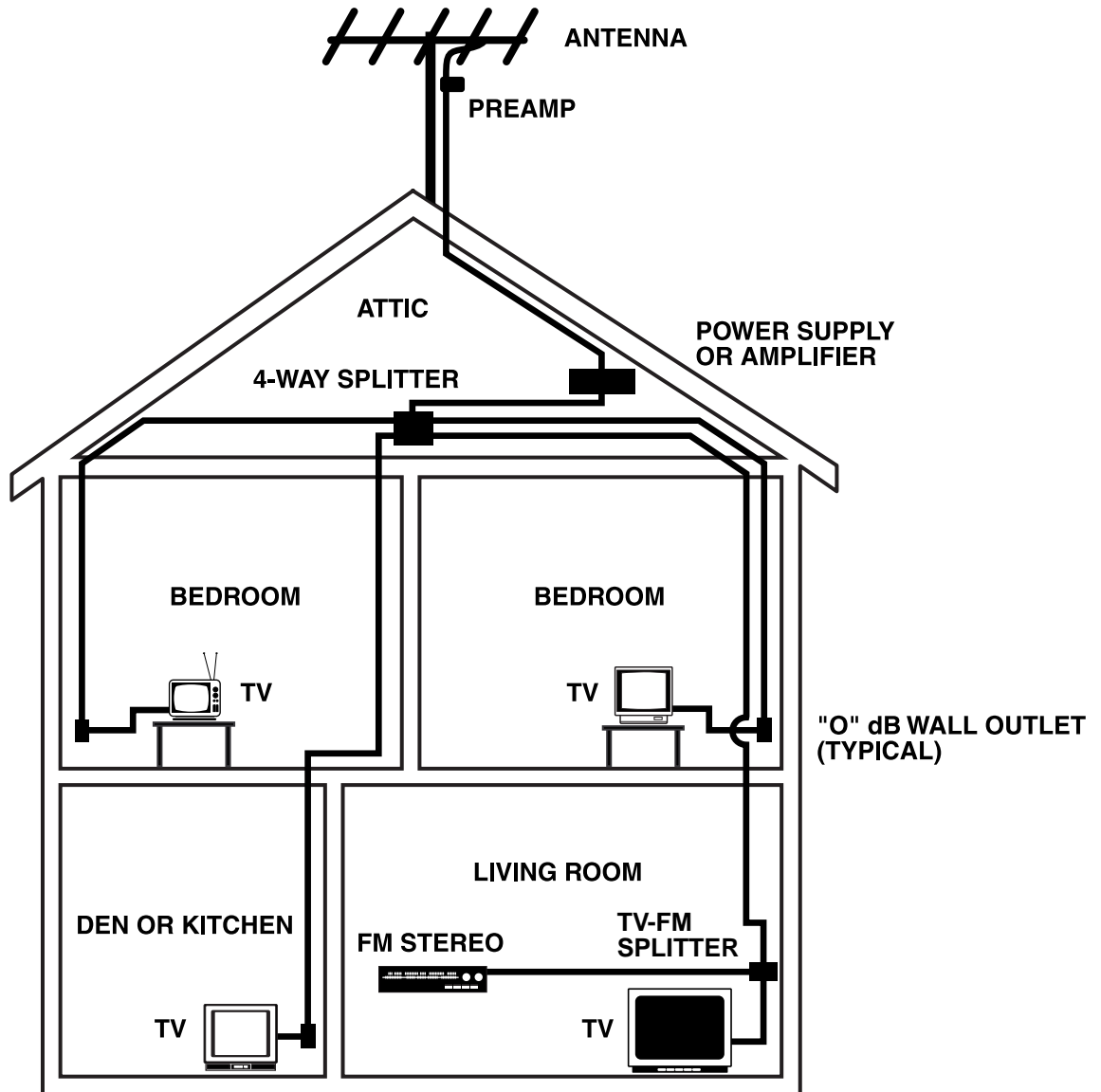

Fig. 10-5. A diagram of a typical medium-sized home MATV system.

CHAPTER ELEVEN: TROUBLESHOOTING

Antenna Systems Interference

There are times when despite all the careful planning and attention you've given an installation, outside interference still shows up on the TV screen. Some of the most common interference problems and their solutions are discussed in this chapter.

GHOSTING

Ghosting is the appearance of faint duplicate images alongside the true picture. Ghosting is caused by two sets of the same signal arriving at the receiver at slightly different times. Leading ghosts (Figure 11-1) appear to the left of the main images. Trailing ghosts (Figure 11-2) appear to the right.



Fig. 11-1. Leading ghosts appear to the left of the main images.

Leading Ghosts

Leading ghosts are caused by signals arriving at the receiver a split-second ahead of the direct (primary) signal. They are usually caused by direct pick up (pick up other than the antenna).

Solution: Take great care with shielding and download splices, etc. and if ghosting is still present, reorient the antenna to minimize ghosts.



Fig. 11-2. Trailing ghosts appear to the right of the main images.

Trailing Ghosts

Trailing ghosts are usually caused by TV signals that bounce off hills or tall buildings. Because these signals take a longer path to the antenna, they show up on the screen a fraction of a second later than the primary signal. Trailing ghosts also can be caused by shorted-out or otherwise defective connections that produce signal mismatch. This type of ghosting also shows up in a distribution system when signals are reflected back through the system by an unterminated output terminal.

Solution: Use terminators on all unused distribution terminals. Use a highly directive antenna (like a Channel Master QUANTUM®) that will not pick up reflected signals. Reorient the existing antenna; slight reorientation often will eliminate the ghosting. As a last resort try a special "ghost killer" antenna.

Smearred or Blurred Pictures

Blurred or smearred pictures (Figure 11-3) are frequently caused by mismatched impedances or improper connections in the transmission line or other equipment.

Solution: Check all connections to ensure that they are tight and not rusted or corroded. Check for and eliminate any crimps or kinks in the download. Be sure that the line has not been crushed by staples and is not bent too sharply. Use only the best quality coaxial cable, hardware, and other equipment to ensure good impedance matching.



Fig. 11-3. Blurred and smearred TV pictures.

INTERFERENCE

Adjacent Channel Interference

Though it is not uncommon, often the signals of one channel will show up as interference on the channel next to it (Figure 11-4). This usually happens only when the receiving antenna is midway between the transmitter towers of two adjacent channels. Because the frequencies of the two channels are relatively close, the TV tuner amplifies both the desired channel signal and that of the adjacent channel. Some older TV tuners which have poorer selectivity, are especially prone to adjacent channel interference. The effect on the screen is the picture of one channel superimposed on the other.



Fig. 11-4. The most common symptom of adjacent channel interference.

Adjacent channel interference may also appear as a "herringbone pattern" on the screen (Figure 11-5). This is caused by the sound carrier of one channel "beating" against the picture carrier of the other. This produces a signal whose frequency is the difference between the two carrier frequencies. The different frequency is passed by the TV receiver and appears as a herringbone pattern on the screen.



Fig. 11-5. A herringbone pattern caused by adjacent channel interference.

Solution: Traps and filters are available that will minimize this type of interference. Using a highly directive antenna and a rotor will also help. A combination of these methods may be necessary in extreme situations.



Fig. 11-6. Co-channel interference.

Co-Channel Interference

Co-Channel interference (Figure 11-6) occurs when a TV set picks up two stations that are broadcasting on the same frequency. The FCC carefully assigns frequencies so stations on the same frequency are in different reception areas. Nevertheless, certain atmospheric and geographical conditions can still cause co-channel interference. The picture of one station will be considerably weaker than that of the other, but the effect is still annoying. Co-channel interference caused by atmospheric conditions usually is sporadic and lasts only a few seconds or minutes.

Solution: Co-channel interference is difficult to completely eliminate. However, a highly directive antenna (one with a high front-to-back ratio) usually minimizes the problem.

Airplane Flutter

Picture flutter and/or roll caused by airplanes is a problem that usually affects only receivers near airports or along other low-level flight paths. It is caused by signals that bounce off low-flying airplanes. These signals add to or cancel out the primary (direct) signals. The TV picture may roll (loss of vertical synchronization) and/or fade in and out (variation of signal strength).

Solution: A highly directive antenna usually will eliminate airplane flutter. However, if the problem is severe, it may be necessary to stack two identical antennas.

CB and/or Ham Radio Interference

Strong, local signals transmitted by Citizens Band (CB) or Amateur Radio (Ham) operators can cause a picture to roll, fade, or disappear completely. Sometimes, horizontal lines appear on the screen (Figure 11-7) and the voices of the radio operators are heard in the TV audio.



Fig. 11-7 Horizontal lines caused by Amateur Radio Interference.

Solution: If you know or can identify the radio operator, call the person and tell him/her about the interference. If the radio operator is cooperative (most are), he/she usually can eliminate the interference by equipment adjustment and/or by installing filters. If the operator will not cooperate or is unknown, call the FCC. If these efforts do not solve the problem, purchase a high-pass filter that eliminates frequencies below 54 MHz. Attach the filter to the input of the receiver or prior to any amplifiers if used.

Electromagnetic Interference

Electromagnetic Interference is the most common form of TV screen disturbance. It causes bright static across the screen (Figure 11-8). Often, it also causes a grinding or whining sound. This type of interference can come from many different sources, including household appliances, power lines, motor vehicles, and hospital equipment. The motors of household



Fig. 11-8. Bright static caused by electromagnetic interference.

appliances such as furnaces, mixers, hairdryers and humidifiers are principal causes of electromagnetic interference. The interference from these devices is carried to the receiver through the house wiring.

Solution: A highly directive antenna often solves this problem if the sources from outside the house and the interference is fed to the set by the antenna. There are other measures you can take, however, if the problem persists. If you suspect power line interference, contact the power company. In most cases their linemen can quickly find the loose connector or clamp that is causing the problem. Remember: The use of coaxial cable reduces the probability of electromagnetic interference.

FM Interference

TV interference from the FM band is also a common type of reception problem. FM interference most frequently affects the TV high band (Channels 7-13), but sometimes a weak Channel 6 will also be affected. FM interference typically causes a "herringbone" pattern on the screen (Figure 11-9).



Fig. 11-9. A herringbone pattern caused by FM interference.

Solution: Use coaxial cable instead of twinlead. Use an FM trap (filter) for severe problems. (See the chapter titled Antenna-Mounted Amplifiers for specific instructions about tuning and installing FM traps.)

Preamp Overload

Preamp overload occurs when the transistorized circuitry of an antenna mounted amplifier is fed an excessively strong signal. On the TV screen, preamp overload looks exactly like FM interference.

Solution: When an installation that includes a preamp seems to be experiencing FM interference, always suspect the preamp. Use a preamp with a high input capability (capacity). The input capabilities of preamps are specified as microvolts (μV). Measure the strength of the overload-causing signal. An FM trap or other filter also may be necessary in extremely troublesome causes. Always mount the FM trap prior to the preamp.

GENERAL TROUBLESHOOTING GUIDELINES

When servicing an existing system, be sure to check the strength and quality of the signals being received and the condition of the equipment being used. Measure signal levels with a field-strength meter. Check general picture quality with a TV set you know is operating correctly. You may find that an improper installation or a change in reception conditions is causing problems that can easily be solved.

Defective components within the customer's TV set can also cause problems. To determine whether the cause of a reception problem is the customer's TV or the antenna system, connect your test TV to the antenna system. Compare the picture on the customer's set with the picture on your test TV. If your test set produces an acceptable picture, the customer's TV set probably is the source of the problem, not the antenna system. Unless you are a qualified electronic technician, do not attempt to fix the customer's TV set. Instead, advise the set owner to call a qualified TV technician. (Some cities and states have laws that prohibit anyone other than a licensed TV technician from repairing TV receivers. Some cities and states also require that antenna installers be licensed.)

CAUTION: Before checking out an antenna system, always disconnect the transmission line from the TV input terminals. Some TV set malfunctions can feed potentially dangerous levels of voltage into the transmission line. This voltage can be high enough to cause severe shock, injury, or even death. If you have a volt-ohm-millimeter (VOM), use it to test for dangerous voltages across the antenna terminals of the TV set. You also can use the VOM to test for shorted and open (broken) conductors in the transmission line.

CHAPTER TWELVE: SELLING & INSTALLING SYSTEMS

Selling and installing TV antenna systems has been, and will continue to be, a profitable business for competent installers who understand and apply proven business management and operating principles.

A few years ago there were predictions that community antenna television (CATV) systems would eventually eliminate the need for home TV outdoor systems. Although CATV is available to homeowners in some metropolitan areas, it is still not available to homeowners in many areas of the country. In addition, many cable systems do not carry local stations.

A recent national survey indicates that most Americans are not satisfied with the quality of their TV reception. Most are also not aware of the availability of home outdoor TV antenna systems that will significantly improve, and in many cases, expand their TV reception. Of those recently surveyed, 95% said that they have never been asked to buy a home outdoor TV antenna.

These facts mean that there still exists today a huge, untapped market for superior performing home TV antenna systems. It is a market in which a competent antenna installer can earn a better-than-average living, while enjoying the independence and prestige that comes from owning your own successful business.

BUSINESS START-UP PROCEDURES

Starting an antenna installation business is not difficult. However, there are a few preliminary steps that you should take to ensure that your business gets off to the best possible start. These steps are outlined here.

Selecting a Business Name

Selecting a business name might seem as simple as adding your own name to the phrase "Antenna Sales & Installation." Nevertheless, give it some serious thought and consider the following pointers:

1. Most lists of business names, including those in the Yellow Pages, are arranged alphabetically. Consequently, names that start with one of the first few letters in the alphabet appear at the top. People searching in the Yellow Pages for a business often call or visit the first one that appeals to them. The nearer your business name is to the top of the list, the greater your chances of being selected.

2. Names that are hard to pronounce usually do not make good business names. Most people are hesitant to call, talk about, or refer to businesses with names

they cannot pronounce. Also, such names generally are harder to remember than familiar, easily pronounced ones.

3. People consciously or unconsciously associate certain names with undesirable stereotyped images of businesses and businessmen. Analyze the business name you select and be sure it is not one that will create an undesirable impression of you or your business.

Facilities and Equipment

At first, to keep overhead and operating expenses as low as possible, you probably should use your home as your office and your garage or basement as your shop and storage area (later after your business income has grown to a level that will support additional overhead expenses, you probably will want to move your business into a more suitable building.)

Place a desk and filing cabinet in an out-of-the-way space in your home. Have the phone company install a business phone. Be sure someone is there to answer it and take messages during normal business hours, or install an automatic phone-answering device or system.

Your business vehicle should be a dependable van-type truck, preferably one with an economical six-cylinder engine. Install racks on top of it so you can secure one or two extension ladders, a large step ladder, long lengths of masts, and any cartoned antennas that will not fit inside the truck. Tools, rotors, short mast sections, boxed coils of transmission line and hardware should be arranged in an easy-to-find manner inside the truck.

In addition to an assortment of common hand tools such as screwdrivers, pliers, and wrenches, you will need various other tools and materials, some which are unique to antenna installation. A list of these tools and materials is provided in Chapter 4.

Insurance

Business liability insurance is necessary to protect you against financial losses resulting from accidental damage to property or injury to other people for which you can be legally held accountable as an antenna installer. You also will need liability and theft insurance on your truck and its contents.

Before you begin your first installation, consult your insurance agent and purchase the types of insurance you need.

Business Bank Accounts

Establish a business checking account, preferably at a bank with which you are familiar. Pay as many business expenses as possible with checks drawn on your business account. This will help ensure complete records and receipts for business expenses.

As soon as your business income permits, establish a business savings account. Later when the growth of your business requires that you borrow money for additional equipment or other needs, you will need to apply for the loan through the business loan officer of your bank. By having both a business checking account and a business savings account at his bank you will improve the chances of your loan being approved.

Record Keeping and Money Management

To save costs you might be inclined to handle the "paperwork" yourself. However, unless you (or your partner) have had bookkeeping and accounting experience, you will be better off turning over the record keeping and accounting to a professional.

A professional bookkeeper or accountant will set up a bookkeeping system suitable for your business and then will periodically post income and expense entries, audit the books, and prepare financial reports that reveal your profit/loss status and your sources of income and expenses. Most accountants will also prepare the income and sales tax reports that local, state and federal governments require you to file. In addition to providing you with a how-it-goes look at your business, the profit/loss and other financial reports are needed for various tax purposes and for borrowing money to expand your business. An accountant also will be able to help you better manage the financial aspects of your business. The "money management" services of an accountant are especially important as your business begins to grow and you must make decisions about when and how to expand it.

Once the books are set up, if you so choose, you or your partner can post income and expense entries in them, bill customers (accounts receivable), and pay expenses (accounts payable).

Licenses and Permits

Most states, counties, and/or cities require that businesses be licensed. Your accountant or another local business owner can tell you what licenses are required in your area and where and how you must apply for them.

In addition to licenses that apply to all retail and/or service businesses, some states and cities also

require special licensing of certain type of businesses, and/or competency certification of certain skilled trades that service the general public. Because antenna installation is a skilled trade, be sure to check with your state or local electronic dealer/servicer association to determine whether special licensing or certification is required in your state or city.

If your state and/or city has a sales tax, you also will have to apply for a sales tax number. (Most electronic parts distributors will ask for your sales tax number to verify that you are purchasing for a business therefore entitling you to wholesale prices.)

Introduce Yourself to Your Local Channel Master Distributor

Visit your local Channel Master Distributor. Introduce yourself and your business to the manager and learn about the products and services that are available to you. Inquire about ordering, payment, and credit policies. Have your sales tax number with you and if the distributor's credit permits giving a new business an "open credit policy account," be prepared to fill out a credit application. This means that you should have a list of credit references who can verify that you are a good credit risk.

Your Channel Master Distributor will be willing to help you plan and cost out the antenna installation you sell and install. He will also be glad to answer any technical questions you have, or he will refer your questions you have, or he will refer your questions to one of the many antenna experts within the Channel Master organization. The people at Channel Master believe that installers are entitled to the best available products and whatever technical support necessary to install superior antenna systems.

SELLING TV ANTENNAS INSTALLATIONS

Some people think that "selling" means talking someone into buying something they don't need and don't want. People have this impression because at one time or another a "high-pressure salesperson" has attempted to con them into buying something.

There is a big difference between "conning" and selling. Selling a needed, quality product at a fair price does not require high-pressure or misleading tactics. All that is required to sell a useful, fairly-priced, quality product is to identify people who need it, and then give them a convenient and comfortable opportunity to learn about it. If you know the merits of your product and can explain why and how it meets the prospective buyer's needs, chances are you'll make the sale and not even realize it until the buyer says, "I'll take it."

If you use only the best quality antennas, masts, hardware, and related components, you should have complete confidence in your products. If you plan and install each system with care, you should have complete confidence in its ability to do what you say it can do. This confidence should make selling a comfortable experience, because you know that your customer will be getting a quality product that will perform as you say it will, and is being sold at a fair price.

Sell Quality, “Not “Cheap” Prices

Although most people are economy-minded, they do not want a “cheap” installation that fails to deliver good reception and needs replacing in a year or two. An installer can quickly get a poor reputation and put himself out of business if his principal sales philosophy is too “undersell the competition.” Installing quality equipment at a fair price is the way to build a thriving business.

Sell “Quality Reception,” Not Technical Jargon

Another important thing to keep in mind when selling antennas is that most consumers are neither knowledgeable about, nor interested in the “technical” aspects of the antenna installation. Most consumers only know that they want clear, crisp, long-lasting TV reception. They judge the quality of an installation by the picture they get on their TV screen. You will sell antennas more successfully if you offer and deliver better reception than a customer is presently receiving. Offer improved reception on the channels already being received and, if possible better reception on more channels.

Referral Through TV Retailers

Timing is important when selling antenna installations. A customer is most likely to buy an antenna installation when he or she is buying a new color TV. Few retailers maintain an antenna department. Often, they will try to avoid the subject of antennas, or they will refer their customers to a local antenna specialist.

This is where you come in. You can become the local specialist who is recommended by TV retailers. (In fact, with the right contacts you can actually get the dealers to sell antennas for you. This will be discussed later in this chapter.)

Color TV sets need good color-quality TV antennas. Most TV retailers know this, but they do not know enough about antennas to make recommendations. Also, few retailers are set up to handle installations. Approach these retailers and offer them your services. Don't hesitate to approach the largest discount stores and the smallest electronics shops. You can offer them a deal that will be mutually rewarding.

Many of the complaints TV retailers and servicers receive about television reception are caused by poor antenna installation. You can take this burden off their shoulders by doing all of their antenna installations and then standing behind your work. The retailer satisfies more customers this way, and his after-sale costs are greatly reduced. Servicers also will benefit from more satisfied customers and few callbacks.

With your installations, a retailer's customers get the best possible reception, which leads to a powerful form of advertising: word-of-mouth. This in turn, generates more TV sales for the retailer and more installations for you.

Getting a retailer to recommend you exclusively is beneficial to both of you. For this reason many retailers and servicers will be receptive to this type of business deal. Getting a retailer to sell antennas and antenna installations for you is a situation that can be even more rewarding.

SELLING ANTENNAS AND INSTALLATIONS THROUGH ESTABLISHED RETAILERS

The best approach to selling TV antennas and installations is to let established retailers do the selling for you in exchange for a mutually agreeable share of the profits. Or, you can sell antenna installations to retailers at “package” prices that include the cost of both materials and installation labor. Retailers in turn, can mark up your package prices to produce whatever profit is necessary and competitive.

The types of established retail outlets that you should attempt to sell through are:

- Mass merchandisers (department and large discount store chains that sell home entertainment electronic products such as TV's, radios, etc.
- Independent retailers who sell home entertainment electronic products (TV dealers).
- Independent servicers of home entertainment electronic products (TV servicers).
- Hardware stores.
- Real estate developers and home builders.

The principal advantages of selling through established retailers are:

- It lets you concentrate your time, energy, and financial resources on doing what you do best—installing TV antenna systems.
- It leaves the actual selling to professional merchandisers and sales people who because of their merchandising-oriented locations, high consumer volume, and facilities, can sell more efficiently and productively.

As an installer, you can buy antennas and related materials at a sizable discount. You can reasonably add 30-40% to antenna prices and sell them to the retailer. He in turn, sells antennas to his customers with whatever additional markup he desires. In this manner, the retailer makes a profit without having to stock merchandise, keep an inventory, or use up valuable floor and warehouse space. This is "gravity" for him and more profits for you.

Department stores offer an even larger market than the average independent retailer. Don't be afraid to approach even the biggest discount and department stores. The person to see is the brown goods buyer or the parts and accessories buyer. It is the responsibility of these individuals to find good deals that will increase profits.

You may have to alter your offer a bit when dealing with a large store. Generally, a department store buyer will want to add a 30-40% markup on anything the store handles. With antennas however, the buyer may be persuaded to work with a smaller profit simply because he doesn't have to inventory and warehouse a large volume of merchandise. The fact that good TV antenna installations help sell TVs (and help keep them sold), may also influence the buyer to keep his markup fairly low. Because this kind of deal can also be very rewarding for you, offering the buyer a generous profit should not be ruled out. You can compensate for a decrease in your own markup by sheer volume of sales.

When you get to know your installation area you will be able to arrive at a figure that will be the "average cost" of an installation. You can then offer a retailer a complete installation package that he can sell to his customers at a profit for both of you.

Let's say for example, that you offer installations to a retailer or store buyer for a flat fee of \$45.00. He will offer the installation to his customers at \$59.95. This will give him a profit of \$14.95 (or 25%). If the antenna costs you \$12.00, the hardware (cable, connectors, etc.) \$8.00, and the labor \$10.00, you have invested \$30.00 in the \$45.00 installation. Your profit is \$15.00 (or 33-1/3%). This is a good profit. You should always try to price installations at least 30% above your cost.

One of the keys to making any relationship with a retailer work is to provide salesmen with the right "tools" to sell antennas. Ideally, the retailer should display, advertise, and sell the antennas (with or without the installation fee figured in). The retailer should also collect money and pay you your share.

You provide the antenna, the hardware, and all other materials. You install the antenna, handle any callbacks, and provide a warranty for the installation. A three-month warranty is customary. However, many installers who use Channel Master products find that they can safely warrant their installations for a full year.

The retailer and his salesmen should be provided with enough information to sell your antenna installations with confidence. Provide them with a map of the area, and indicate the types of antenna installations that are necessary for the best reception in various zones. Once you know your area this will be easy. You may even want to make a survey with a test antenna, a field-strength meter, and a portable TV. Buy a map and indicate the types of antennas and installations you believe are needed in various areas or zones. However, do not divide the map into too many zones. Five zones should be sufficient for a "medium-sized" city. Using too many reception zones will confuse salesmen and customers. When deciding on an antenna for a zone that has a number of possibilities, choose the larger antenna. It is better to make an error on the side of assured quality reception and a slightly higher cost. Most retailers would rather charge a little more than hear even one customer complaint.

In some exceptionally difficult reception zones, the type of antenna and other equipment required may differ from block to block. In other areas, it may be impossible to guarantee the elimination of ghosts or other types of interference. Label these zones on the map as "Survey Needed" and instruct the installer and salespeople not to close a sale to customers who live in these sectors. Customers can be advised that an installation is available, but the installer first must survey the site to determine the requirements for good reception. Charge only a nominal fee for such a survey. After completing the survey, give the customer an estimate of the total cost. The survey fee might then be credited toward the price of the installation as an incentive for the customer to purchase the system you propose.

If you must offer a choice of antenna don't offer more than three or four. Too many options will confuse both the salesman and the customer and might cause the customer to postpone the purchase. Make it easy for customers to buy and for salespeople to sell. Offer options such as MATV, FM stereo hookups, etc.

Encourage the retailer to display one or more antennas on his sales floor. A good in-store display like that in Figure 12-1 will encourage customers to ask about additional equipment. Try a window display too. Antenna distributors and manufacturers often can supply a large assortment of in-store display materials. Channel Master, for example, offers an attractive line of “Do-It-Yourself” displayed products. Examples of these are shown in Figure 12-2.



Fig. 12-1. Attractive in-store displays combined with colorful self-sell packaging encourages add-on equipment sales.



Fig. 12-2. Channel Master offers an attractive line of “Do-It Yourself” packaged products. (Available through your Channel Master Distributor.)

Most of your antenna sales through TV retailers will be to purchasers of large-screen color TVs and those consumers looking to supplement their DBS (Digital Broadcasting System) set ups. However, don't let the retailer overlook antenna sales to purchasers of portable TVs. The retailer's salesman should be made aware that a good outdoor antenna system is as necessary for a small-screen set as it is for a large-screen.

Sign up as many retailers as possible. The more business you do, the more efficient and profitable your operation will become. However, don't take on more jobs than you can handle. It takes time to find and adequately train people to install antenna systems. Also, a beginning business usually will not be able to obtain financing for the large amounts of expensive equipment needed to put additional screws to work. Plan and prepare for growth in small steps.

Keep customer satisfaction foremost in your mind. A customer who buys a new color TV will probably want to watch his set on the evening of the delivery date. If possible, coordinate your installation with the delivery of the new TV. If you can get the antenna installed before the set arrives, you will have a very happy customer and a pleased dealer. It is also easier for the service technician to adjust the new TV if it is connected to an outdoor antenna installation that delivers adequate signals on each channel.

Remember that your reputation is affected by each installation. Don't keep customers waiting, but don't hire incompetent help at the last minute to keep you from falling behind schedule. Department stores and independent TV dealers don't want headaches, and they won't tolerate any work that causes unhappy customers.

No matter how much business you get through retailers, you should also go after as many direct sales as your time and other resources permit. Every direct sale you make eliminates a commission you have to pay someone else. It will also help you maintain a degree of independence that will not be possible if you rely solely on retailers for your business. Direct sales offer you an opportunity for greater profits and the ability to adjust your prices to remain competitive when market conditions demand that you slightly lower your prices and/or profit.

Direct sales demand that you advertise. The most effective advertising generally is in the Yellow Pages and in newspapers. Below are some important points about advertising that you should consider.

ADVERTISING

Advertising is not a cost, it is an investment. Even the best installer with the best equipment and materials won't succeed unless he makes people aware of this products and services and the advantages they will realize by doing business with him. Build your business by letting people know who you are, what you can do, how well you can do it, when you can do it, and at what price.

A well-chosen business name is important. Some businesses spend a large amount of money to develop a name and logo. (A logo is the stylistic way your company name is printed.) As a new businessman, you probably will not be able to afford to spend much money developing your company name and logo, but you should invest some thought, time and effort in it.

When you decide on a name, work with a local artist to develop a logo. Look at the names, logos, letterheads, and ads of companies that you recognize and respect. Try to develop an attractive logo that is both simple and up-to-date. Use your logo on all your business cards, letterheads, newspaper and Yellow Page ads, invoices, and store displays. Put it on your vehicles and uniforms. Wear clean, neat work uniforms printed with your company logo and the brand name of the antenna line you carry. You and your crew should wear these uniforms on every job.

Have your logo, business address, and phone number painted on your trucks. Also include the logo of your antenna line and a short, attention-getting slogan that tells people why they should do business with you. For example, your slogan might stress "quality TV reception at reasonable prices."

Print some small but conspicuous signs that have a small holder for your business cards. Get permission to place these signs in as many big traffic places as possible. Bulletin boards in supermarkets, housing development offices, and small "quick-stop" markets are ideal places.

The retail establishments that sell antennas for you probably make regular mailings to their customers and potential customers. Encourage these stores to include information about the availability of antennas and antenna installations in their mailings. Also, preprinted mailers for use in your own direct-mail advertising are available from your local Channel Master Distributor.

Probably the best way to reach potential customers is through the media—newspapers, radio and television. Local TV and radio stations and newspapers will help you develop a hard-hitting ad campaign.

Local TV servicers can also help spread your name around. Customers frequently ask them to recommend someone to install an antenna system. The TV technician who has just repaired a customer's TV set is in the best possible position to recommend an antenna installer, and his customers generally consider him an expert on such matters. Also the servicer's recognition of an antenna-related reception problem gives him an opportunity to suggest a new antenna.

Electricians, house builders, plumbers, and general contractors also are good mediums for word-of-mouth advertising of your services and products. Many of the homeowners or businessmen with whom they do business may need an antenna or MATV system, particularly those who are in the process of having a new home or business facility built. If these businessmen in your area know who you are and know that you do good work, they will recommend you, especially if you reward them with a "referral fee."

CAUTION: Any businessman who recommends you is staking his own reputation on your ability to do quality work. Consequently, you owe it to yourself, your customers, and your business associates to do the best possible job every time. Word-of-mouth advertising is vital, but it can also work against you.

GROWTH DEMANDS ADDING INSTALLATION CREWS

Plan the growth of your business very carefully. As you grow, you'll need to hire additional people. When building up a work force, divide your installers into two-man crews and provide each crew with a fully-equipped truck. The senior member of each crew should be well-experienced and well paid. The other member of the crew should be paid a wage that is fair for someone who is learning the business.

The average crew should be able to handle five or six installations a day, although this will depend on the distances traveled and the type of installations. For example, it may take a two-man crew all day to complete one tower installation.

Providing monetary incentives for extra installations builds morale and improves productivity. Any complaints or callbacks should be handled by and charged against the incentive pay of the crew that did the job. This is a fair way of enforcing the need for quality work.

CONSULT YOUR CHANNEL MASTER DISTRIBUTOR

If you have technical or marketing questions or problems during the start up or growth of your business, contact your Channel Master Distributor for a Field Representative. Our technical and sales forces have been responsible for the successful start up and growth of some of the largest antenna installation businesses in the country. Antennas and antenna systems are our business. The more you sell and install, the more it helps both of us.

GLOSSARY OF ANTENNA SYSTEM TERMS

Acrylic Insulator—A plastic material that is used to weatherproof outdoor antenna system connections. It is applied in liquid form, typically by aerosol can.

Alignment Bearing (rotor)—A ball bearing-equipped guy ring that is slipped onto the antenna mast above the rotor to permit guying of the mast section rotated by the rotor.

Antenna Discharge Unit (Lightning Arrestor)—A small device that is inserted into the transmission line and connected to a grounding wire or strap to discharge static electricity to ground before it can enter and damage a TV receiver.

Array, Multiple—See **Multiple Array**.

Attenuation—A decrease in the strength (level) of a signal as it is transmitted or carried by wire(s) from one point to another. In antenna systems, attenuation is usually an undesirable characteristic.

Balun (matching transformer)—A small device that matches the impedance of one component, transmission line, or circuit to that of another to prevent loss of signal strength and other unwanted characteristics. In antenna systems, baluns typically are used to match 75 ohm coaxial cable to the 300 ohm output of an antenna or the 300 ohm input of a TV.

Band, Low (TV)—See **Low Band**.

Band, High (TV)—See **High Band**.

Beamwidth—The angle formed by the two compass directions that outline the boundaries of the area from which the front of an antenna can intercept signals and deliver them to the output at relatively equal levels. Generally, the narrower the beamwidth of an antenna, the greater the directivity and gain.

Boot, Weather—See **Weather Boot**.

Brown Goods—A wide variety of consumer electronic products that traditionally have brown or darker cabinets than home appliances such as refrigerators, washers and dryers. Examples of brown goods are TV receivers and radios.

Carrier, Picture (TV)—See **Picture Carrier**.

Carrier, Sound (TV)—See **Sound Carrier**.

Coaxial Cable (coax)—A type of round transmission line composed of a central conductor (wire)

surrounded in turn by an insulating material (dielectric), and a metallic shielding material which typically is braided and acts as the second conductor. (Some types of coaxial cable have an aluminum foil shield under which is run a separate wire strand that serves as the second conductor.) These elements, in turn, are covered by a thin layer of insulating and weatherproofing material such as polyvinyl. Coaxial cables used as home TV transmission lines have an impedance of 75 ohms.

Decibel (dB)—A measurement term that describes the strength (level) of a signal in logarithmic relation to a reference strength (level). For example, when the signal strength is expressed in micro-volts, an increase of the signal strength by 6 dB means that the signal strength has been doubled.

Dielectric—An insulating material placed between conductors to prevent the conductors from physically contacting one another (shorting out). In coaxial cable, insulating material surrounds the central conductor to prevent it from touching the metallic shield (and other conductor wire if one is used.) The insulating material also maintains a specific amount of space between the central conductor and the other conductor. This spacing is necessary to maintain certain cable characteristics that if changed, will decrease the quality of the signal.

Dipole—The element(s) of an antenna that intercepts the signal and feeds it to the antenna output terminals. The other elements of the antenna serve as “director” and “reflector” which direct or reflect the incoming signal to the dipole element.

Directivity—The ability of an antenna to pick up signals from one general direction (usually from the front) and effectively reject those from other directions (usually from the back and sides). The front-to-back ratio is one measure of an antenna’s directivity.

Discharge Unit, Antenna—See **Antenna Discharge Unit**.

Distribution Amplifier—An amplifier that is mounted indoors to boost the strength (level) of the received signal so that it can be fed to two or more receivers.

Drip Loop—A short, U-shaped loop of a wire (or cable) immediately adjacent to a house entry point or electrical connection, so that water will drain off of the wire and not run into the house or connection.

Element, Antenna—The small, hollow metal rods of various lengths that are attached (usually perpendicularly) to the main horizontal support member (boom or crossarm) of the antenna. The element at the rear of the antenna (called reflector) is usually the longest. The element that actually feeds the intercepted signal to the antenna output is called a dipole.

F-Connector—A small, metallic, male-type connecting device with internal threads that attach to the end of a coaxial cable to secure and electrically connect the coax to a female F-fitting. The internal threads of the male connector screw onto the external threads of the female connector. Most baluns have a female-type F-connector on one end for the 75 ohm coax, and terminal lugs on the other end for 300 ohm twinleads.

Field Strength Meter—An electronic instrument that measures the strength of a signal and indicates it on a meter calibrated in microvolts (uV) or decibels (dB). (See Microvolt/Decibel.)

Filter, High-Pass—See **High-Pass Filter**.

FM—The term means frequency modulation. In relation to television and antenna systems, “FM” refers to the frequency modulated signal (FM radio stations whose frequencies lie in a band between TV channels 6 and 7).

Front-to-Back Ratio—A measure of the directivity of an antenna that is based on the difference between the strengths of signals received from the antenna front and those received from the back. The difference usually is expressed in decibels (dB). For example, a front-to-back ratio of 40 dB indicates that the output strength (in uV) of signals received from the antenna front will be 100 times greater than those received from the back. Generally, the higher the rating in dB, the greater the directivity of the antenna.

Gain—An increase in signal strength. The “gain” of an antenna indicates how much more signal strength it delivers to the output terminals than would a single-element antenna (a dipole) under the same reception conditions. Antenna gain usually is expressed in decibels (dB). For example, an antenna with 10 dB gain will deliver 3.2 times more signal strength to the output terminals than will a single-element antenna.

Ghosts (ghosting)—Faint duplicate images that appear in a TV picture to either the left or right of the desired picture image.

Ground Rod—A long metal rod that is driven into the ground near an antenna installation and to which is attached the grounding wires from the mast and antenna discharge unit to discharge static electricity to ground before it can enter and damage the TV receiver.

Guy Wire (Guying)—Three or more multi-strand steel or aluminum wires that are connected between the guy ring(s) on the antenna mast and widely spaced eye screws in the house roof, supporting the mast against the forces of wind and ice.

Guy Ring—A circular metal collar with attachment holes (eyes), that is slipped on and clamped to an antenna mast. Guy wires are then attached to the mast through the holes in the guy ring.

High Band TV—The band of frequencies assigned to VHF TV channels 7 through 13 by the Federal Communications Commission (FCC).

High-Pass Filter—A device that is connected to a transmission line to filter out interfering signals whose frequencies are below those in the TV band. High-Pass Filters typically are used to filter out interference caused by Amateur and Citizens Band radio transmission.

Impedance—A signal-affecting characteristic that is present to some degree in all electrical conductors (wires) and electronic circuits. Impedance is usually expressed as so many ohms. To prevent an unnecessary decrease in the strength of a signal that is being transferred (coupled) from one type of conductor or circuit to another, the difference in impedance must be “matched” by a device that compensates for the differences in the impedances. A balun is used in antenna systems to compensate for the differences in impedance between a 300 ohm antenna and a 75 ohm coax, and between a 75 ohm coax and the 300 ohm input circuit of a TV receiver. Impedances that are not the same, or whose differences have not been compensated for, are said to be mismatched.

Input Capability, Preamp—The maximum strength of signal, in microvolts (uV), that an antenna preamp can accept without “overloading.” (Overloading causes distortion, reduction, or complete elimination of the signal.)

Insulator, Acrylic—See **Acrylic Insulator**.

Interaction, Signal—The interfering effect that one signal has on another when two different signals are present at the same time in a conductor (wire) or circuit. Signal interaction in the transmission line of a TV antenna system causes picture problems such as ghosting, smearing, snow, and various forms of interference patterns.

Line, Transmission (TV)—See **Transmission Line**.

Low Band (TV)—The band of frequencies assigned to VHF TV channels 2 through 6 by the Federal Communications Commission (FCC).

Lug, Terminal–See **Terminal Lug**.

Mast, Antenna (TV)–A vertical section (or sections) of tubular steel or aluminum on which the antenna is mounted. Most sections typically are available in 5 and 10 ft. lengths.

Matching Impedance–See **Impedance**.

Matching Transformer (TV)–See **Balun**.

Microvolt (uV)–One millionth of a volt, or 0.000001 volt. The strength of the signals in a TV antenna system is expressed as so many microvolts (uV). Generally, to produce an acceptable TV picture, the strength of the TV signals at the input terminals of a TV set must be at least 1000 microvolts (uV).

Mismatch, Impedance–See **Impedance**.

Multiple Array–Two or more antennas mounted on the same mast with outputs coupled together. Multiple arrays are used to increase gain (signal strength) and directivity.

Noise Figure–Generally, a numerical rating that indicates how much electromagnetic “noise” there will be at the output of a circuit or system compared to the noise at the input. If the strength of the noise is too near that of the picture-producing signal, noise-produced specks, called “snow,” will be produced on the TV screen. The lower the noise figure of a circuit, system, or component, the lower the output noise level will be compared to the output signal level and in turn, the lower the probability of snow on the screen of the TV set.

Ohm–The unit of measure of resistance and impedance. (see **Impedance**).

Omni-directional (Antenna)–An antenna capable of intercepting signals from all compass directions equally well. Such an antenna is nondirectional.

Orangeburg–A type of black pipe that is made of asphalt-like material and is used for gas vents and sewers in homes and commercial buildings.

Orient (an antenna)–To aim the antenna in a specific direction, usually toward the transmitting tower(s) of the TV stations.

Overloading of Preamp–See **Input Capability, Preamp**.

Overloading of Receiver–See **Receiver Overload (TV)**.

Passive Device–Any signal-handling device (in an antenna installation) that is not electrically powered and therefore, does not increase the strength of the

signal. Couplers and splitters are examples of passive devices.

Picture Carrier (TV)–The part of a TV signal that contains the video (picture) information. (The audio (sound) is contained in the sound carrier.)

Pitch Pad–A small piece of neoprene or other “rubbery” material that is placed under the legs of a tripod roof mount to cushion the mount and seal around the anchor bolts that secure the legs to the roof.

Plaster Strap–A non-metallic strap that is used to secure wall connectors for 300 ohm twinlead. (Metal straps cannot be used with twinlead because they affect its signal-handling characteristics.)

Plumb Bob–A metal weight (usually cone-shaped), that is attached to a length of cord or string and hung free from a height to determine whether the line between two points or the position of a vertical structure is truly vertical.

Polar Plot–A flat graph that provides a bird’s-eye view of antenna performance characteristics such as directivity and beamwidth.

Preamp, TV (Preamplifier)–A small amplifying device that is mounted on the mast or antenna boom as close to the antenna output terminals as possible, so that the strength of a very weak signal is increased (amplified) before it enters the transmission line. Without this preamplification, the strength of the already weak signal (1000 uV or less) would be further reduced as it passes through the transmission line producing “snow” on the TV screen.

Rafter–One of the parallel beams that form the slope of a roof.

Rear Rejection–The ability of an antenna to reject (not receive) signals that approach it from the back.

Receiver Overload (TV)–A condition in which excessively strong signals cause the picture on the TV receiver to lose synchronization (vertical and horizontal roll) or disappear completely. Older model receivers are more likely to overload than are newer ones. Frequently, this condition can be eliminated by readjusting the receiver’s automatic gain control (AGC).

Rotor Alignment Bearing–See **Alignment Bearing, Rotor**.

Sensitivity, Antenna–General classifications of relative antenna gain that indicate approximately how far from the station transmitter tower(s) an antenna designed to be used. Examples of these classifications are suburban, fringe, and deep fringe.

Signal Mismatch—A condition in which an antenna system delivers signals whose strengths and general quality vary. This usually is the result of incorrectly installed signal-distribution components. (See Interaction, Signal.)

Sound Carrier (TV)—The part of a TV signal that contains the audio (sound) information. (The picture information is contained in the picture carrier.)

Standard Household Current (117V/AC)—The type of electrical power that is delivered to and operates appliances, lighting, electrical outlets and other electrical devices in a home. It is called alternating current (AC), and its normal value is 117 volts.

Standout (Standoff)—A metallic device with wood-screw threads or a clamp on one end and a circular loop (eye) with slotted insulating material on the other. It is used to secure and hold 300 ohm twinlead or other unshielded transmission line away from metal gutters, walls and other surfaces that can change the line's signal-handling characteristics. The standout is screwed into a wall or other part of the house or is clamped onto the antenna mast. The transmission line then is inserted in the slot of the insulating material in the eye.

Star Bit—A steel, punch-like device that is hit with a hammer to "drill" holes through masonry (brick, cement block, etc.)

Switchable Trap—A small device that is used with a preamp to eliminate (trap out) an unwanted bank of signals. It is called "switchable" because it can be switched on or off (although this is difficult because the trap is mounted with the preamp up near the antenna). A switchable trap usually is used to eliminate the FM band

Tandem System—A preamp and a distributive amplifier that are designed to be used together.

Tensile Strength—The ability of a material or structure (such as an antenna mast) to withstand large bending forces without distorting or breaking apart. Tensile strength is an important factor to consider when selecting a mast and planning an installation.

Terminal Lug—A two-pronged connective device that is used to secure a wire to an electrical terminal. One end of the device is crimped onto the bared wire. The two flat prongs then are slipped around the terminal screw, and the screw head is tightened down against the prongs, securing the electrical connections.

Transmission Line—A two (or more) conductor wire that is used to carry current or signals from one point to another. Twinlead and coaxial cable are the most common types of transmission line used to carry TV signals from the antenna(s) to the receiver.

Tunable Trap—A small device that can be tuned (adjusted) to eliminate any one of the number of frequencies within a band. Tunable traps are frequently used with preamps, to eliminate a particularly troublesome signal.

Twinlead—A type of unshielded ribbon-like transmission line that consists of two insulated conductors (wire) separated by a thin, flat expanse of insulating material. TV twinlead has a characteristic impedance of 300 ohms, and therefore is called 300 ohm twinlead.

UHF (TV)—UHF means ultra-high frequency. When used in relation to TV, UHF refers to channels 14 through 69, whose frequencies are located in the UHF band. Modern TV receivers have two separate tuners, one for VHF (channels 2 through 13), and one for UHF (channels 14 through 69). Although the UHF tuners of some television receivers can also be tuned to channels 70 through 83, there are no TV signals on these channels because the FCC has reassigned their frequencies to other uses.

UHF/VHF (TV)—An indication that a TV receiver or antenna is capable of receiving both the UHF and the VHF channels.

VHF (TV)—VHF means very-high frequency. When used in relation TV, VHF refers to channels 2 through 13, whose frequencies falls within the VHF band. The TV VHF band is divided into two subbands: (1) the low band, which includes channels 2 through 6 and a frequency range of 54 MHz-88 MHz, and (2) the high band, which includes channels 7 through 13 and a frequency range of 174 MHz-216 MHz. A portion of the frequency band between channels 6 and 7 is used for FM radio stations.

VHF/FM Broadband Antenna (TV)—A TV antenna that is capable of receiving the complete TV VHF band (channels 2-13) and also the FM band (88 MHz-108 MHz).

VHF/UHF/FM (TV)—An indication that a TV receiver or antenna is capable of receiving all VHF channels (2-13), all UHF channels (14-69), and FM band (88 MHz-108 MHz).

Weather Boot—A rubber-like covering that is used to protect outdoor electrical connections from the weather (rain, ice, etc.).

TELEVISION CHANNELS

Channel Number	Frequency Band MHz	Picture Carrier MHz	Channel Number	Frequency Band MHz	Picture Carrier MHz	Channel Number	Frequency Band MHz	Picture Carrier MHz			
Low Band	2	54-60	Hyper Band	II	348-354	UHF		43	644-650	645.25	
	3	60-66		JJ	354-360			349.25	44	650-656	651.25
	4	66-72		KK	360-366			355.25	45	656-662	657.25
	5	76-82		LL	366-372			361.25	46	662-668	663.25
	6	82-88		MM	372-378			367.25	47	668-674	669.25
	FM	88-108		NN	378-384			373.25	48	674-680	675.25
Mid Band	A	120-126		OO	384-390			379.25	49	680-686	681.25
	B	126-132		PP	390-396			385.25	50	686-692	687.25
	C	132-138		QQ	396-402			391.25	51	692-698	693.25
	D	138-144		RR	402-408			397.25	52	698-704	699.25
	E	144-150		SS	408-414			403.25	53	704-710	705.25
	F	150-156		TT	414-420			409.25	54	710-716	711.25
	G	156-162		UU	420-426			415.25	55	716-722	717.25
	H	162-168	WW	426-432	421.25	56	722-728	723.25			
High Band	I	168-174	VV	432-440	427.25	57	728-734	729.25			
	7	174-180	14	440-446	435.25	58	734-740	735.25			
	8	180-186	15	476-482	471.25	59	740-746	741.25			
	9	186-192	16	482-488	477.25	60	746-752	747.25			
	10	192-198	17	488-494	483.25	61	752-758	753.25			
	11	198-204	18	494-500	489.25	62	758-764	759.25			
	12	204-210	19	500-506	495.25	63	764-770	765.25			
	13	210-216	20	506-512	501.25	64	770-776	771.25			
	J	216-222	21	512-518	507.25	65	776-782	777.25			
	K	222-228	22	518-524	513.25	66	782-788	783.25			
	L	228-234	23	524-530	519.25	67	788-794	789.25			
	Super Band	M	234-240	24	530-536	525.25	68	794-800	795.25		
		N	240-246	25	536-542	531.25	69	800-806	801.25		
O		246-252	26	542-548	537.25	70	806-812	807.25			
P		252-258	27	548-554	543.25	71	812-818	813.25			
Q		258-264	28	554-560	549.25	72	818-824	819.25			
R		264-270	29	560-566	555.25	73	824-830	825.25			
S		270-276	30	566-572	561.25	74	830-836	831.25			
T		276-282	31	572-578	567.25	75	836-842	837.25			
U		282-288	32	578-584	573.25	76	842-848	843.25			
V		288-294	33	584-590	579.25	77	848-854	849.25			
W		294-300	34	590-596	585.25	78	854-860	855.25			
Hyper Band	AA	300-306	35	596-602	591.25	79	860-866	861.25			
	BB	306-312	36	601-608	597.25	80	866-872	867.25			
	CC	312-318	37	608-614	603.25	81	872-878	873.25			
	DD	318-324	38	614-620	609.25	82	878-884	879.25			
	EE	324-330	39	620-626	615.25	83	884-890	885.25			
	FF	330-336	40	626-632	621.25						
	GG	336-342	41	632-638	627.25						
HH	342-348	42	638-644	633.25							
				639.25							

Picture Carrier = Lower Frequency + 1.25 MHz

Color Carrier = Picture Carrier + 3.579 MHz

Sound Carrier = Picture Carrier + 4.5 MHz

CATV channels shown in parenthesis.